

安装孔尺寸

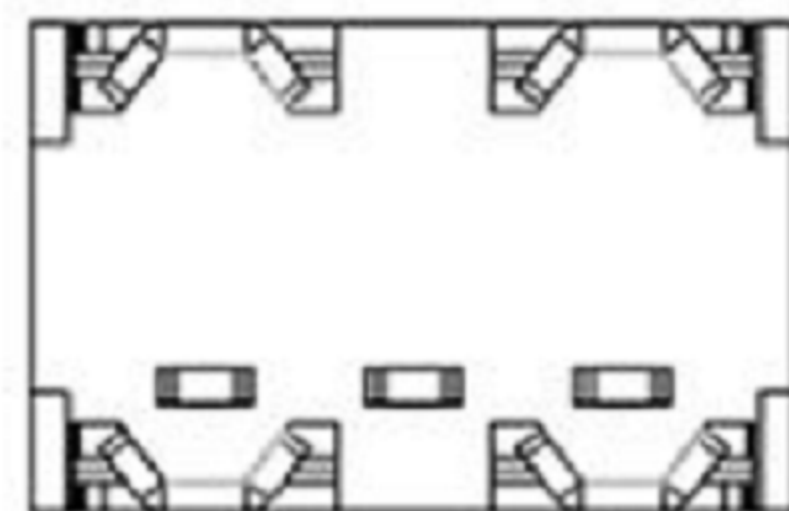

手柄位置及导通端子示意图

	POS. 1	POS. 2	POS. 3
Model NO.	键槽		
103	ON	OFF	ON
SCHEMATIC		OPEN	

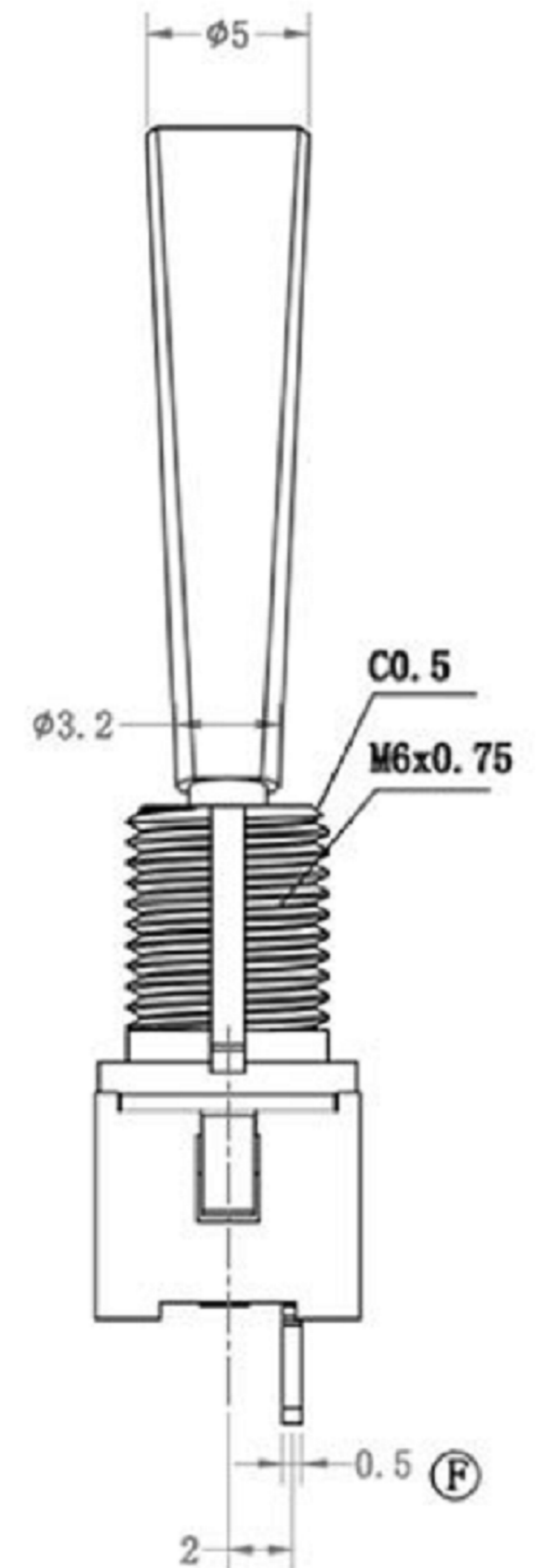

标注 A - F 为重点尺寸

Technical characteristics

SPECIFICATION: 0.1 A max. @ 12 VDC.
 MECHANICAL LIFE: 20,000 make-and-break cycles.
 CONTACT RESISTANCE: 50mΩ max. initial @2-4VDC
 100mA for both silver.
 INSULATION RESISTANCE: 100 MΩ min.
 DIELECTRIC STRENGTH: 1000 VAC min.
 OPERATING TEMPERATURE: -30°C to +85°C.

Materials

CASE: PA6T.
 HOUSING: Stainless Steel.
 ACTUATOR: Alloy, Black zinc plated.
 BUSHING: Alloy, Black zinc plated.
 CONTACT/TERMINALS: Copper alloy silver plated.

RoHS



东莞市高迪电子有限公司
 DONG GUAN GAO DI ELECTRONICS CO., LTD

TOLERANCE UNLESS OTHERWISE STATED:
 Up to 5 ±0.2
 Above 5 ~ 15 ±0.3
 Above 15 ~ 30 ±0.4
 Above 30 ~ 50 ±0.5
 Angle ±0.3°

3RD. ANGEL'S

UNITS MM

DRAWN BY:	DATE	MAT'L	TITLE	Medium sized switch
Ming Ming Zou	07/23/13			
CHECKED BY:	DATE	FINISH	MODLE	Medium sized switch
Ning Ning Su	07/23/13			
APPROVED BY:	DATE	SCALE	DWG NO.	GD-DTS-113-E001-T000-RS
Jia Xiang	07/23/13	1:1		
SHEET NO.	1 of 1	PART NO.		

ITEM NO.	DESCRIPTION	DRAWN	DATE
2	公差及料號更新	Jack	072313
1	圖面更新	Frank Wu	021012