

REV	DESCRIPTION	DESIGN	DATE
A	NEW RELEASE	FangSongLe	2020/09/23

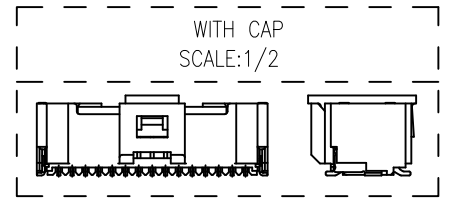

Specifications:
 Poles: 20 to 50
 Contact resistance: ≤20mΩ
 Insulation resistance: ≥100MΩ
 Rated voltage: 50V AC DC
 Rated current: 0.8A AC DC
 Withstand Voltage: 250V AC/minute
 Temperature Range: -25°C ~ +85°C
 Housing: PA9T UL94V-0, Natural
 Contacts: Phosphor Bronze / Gold-plated
 Solder tabs: Brass / MATTE Sn-plated
 Cap: PA9T UL94V-0, Natural

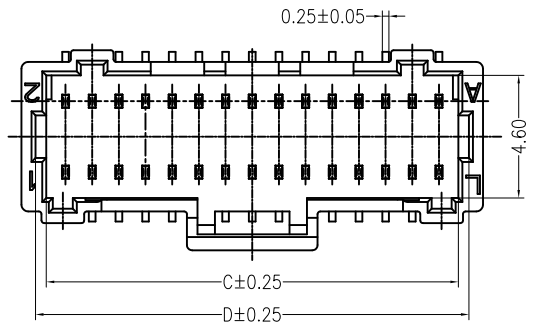
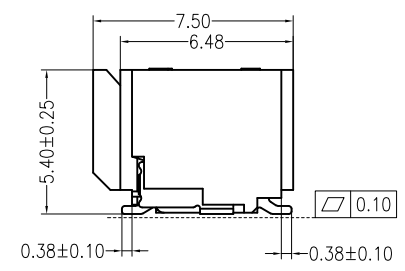
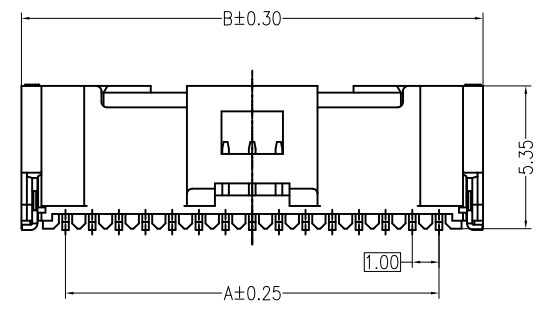

ORDER INFORMATION:

A1008AWV-2-D1CC1-R-X**

PART No.	X: CAP
No. OF CIRCUITS:	PACKAGING:
20-50P	R= REEL
PLASTIC MATERIAL:	Metal code:
D1C=PA9T	1= Phosphor Bronze
	PLATING:
	C= Gold

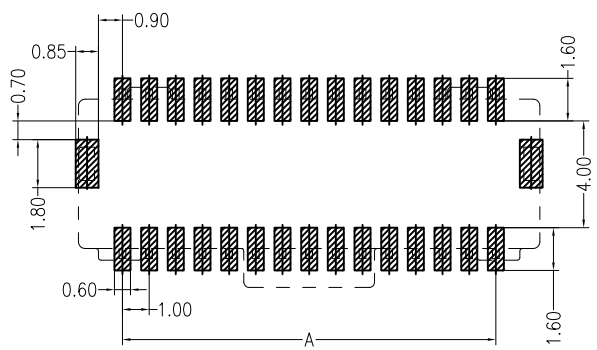
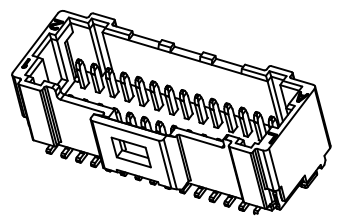
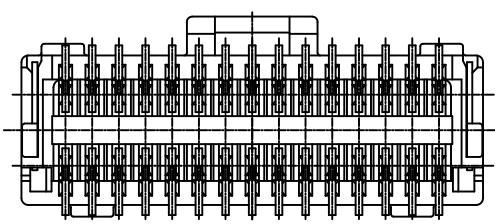

PCB LAYOUT (Tolerance: ±0.05)

PIN.	DIM A	DIM B	DIM C	DIM D
2x10P	9.00	12.30	10.45	11.25
2x15P	14.00	17.30	15.45	16.25
2x20P	19.00	22.30	20.45	21.25
2x25P	24.00	27.30	25.45	26.25

東莞市高迪電子有限公司 DONG GUAN GAO DI ELECTRONICS CO., LTD		TITLE:	
		1.00 Pitch Wafer 180° SMT	
GENERAL TOLERANCE		USE:	
X. ±0.50	X. ±5°	CUSTOMER	
X.X ±0.30	X.X ±2°	APPD: Liuzhengling	
X.XX ±0.20	X.XX ±1°	CHKD: Steven	
UNITS: mm		DR: FangSongLe	
		PART NO.:	
		A1008AWV-2**-D1CC1-R-X	
		DWG NO.:	
		GCKH-0852	
		SCALE	SHEET
		1 : 1	1 / 1

REV	ECN No.	DESCRIPTION	DESIGN	DATE
A		Release	蒋建银	2021.07.22

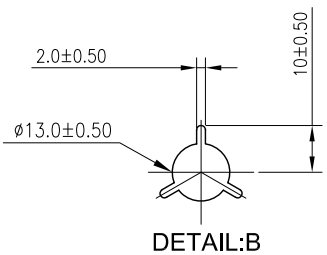
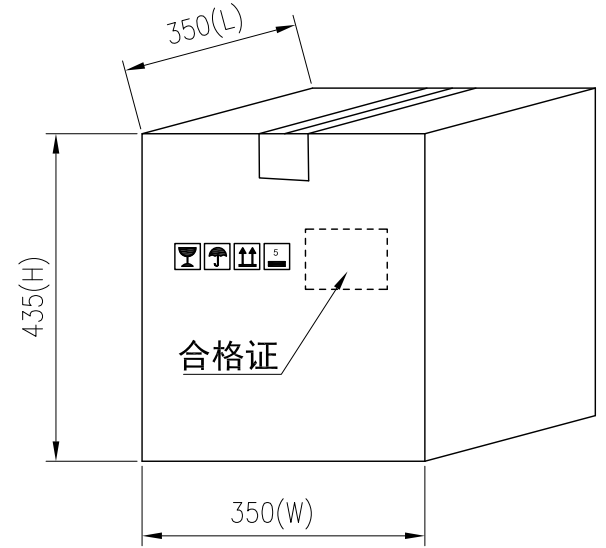
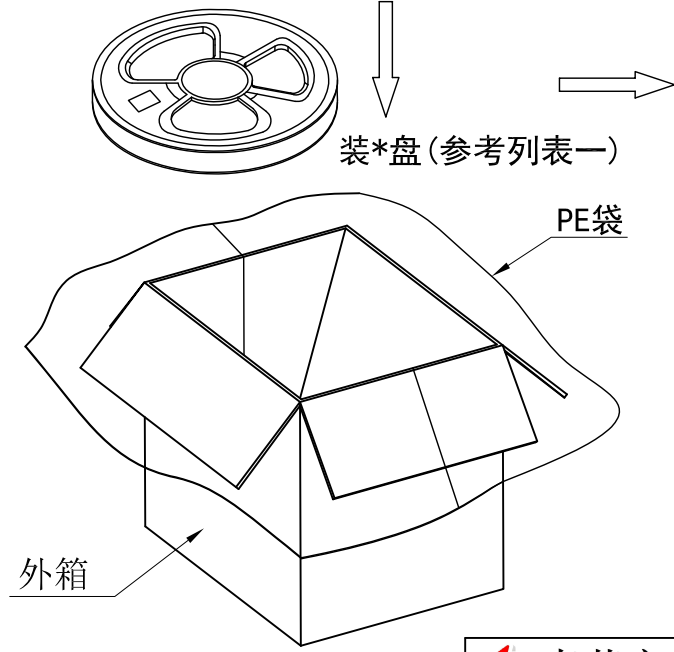
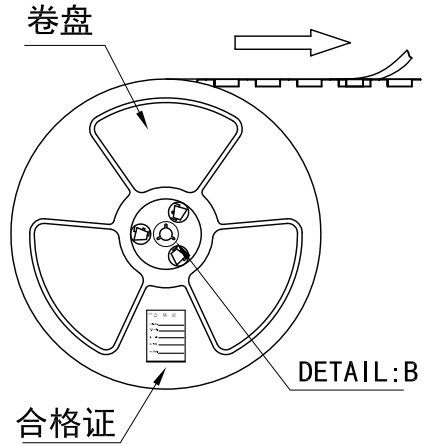
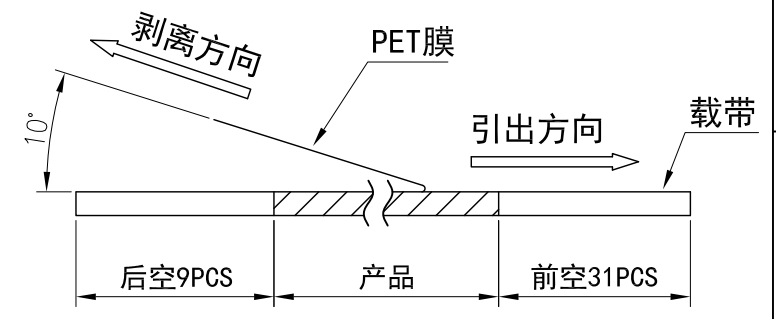
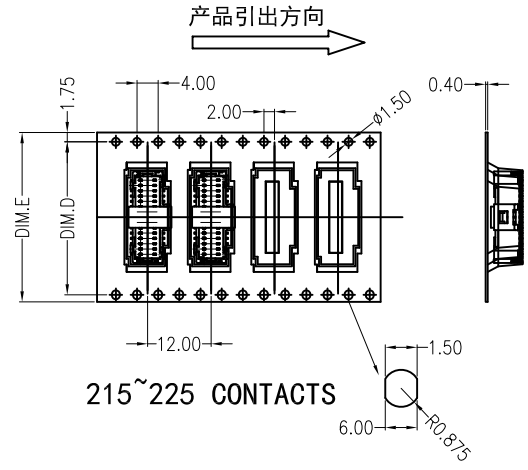
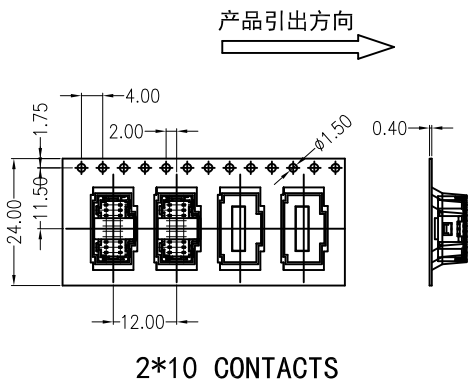

列表一

Circuits	DIM. D	DIM. E	Q'ty/Reel	Packing (Reel/Caton)
2*10PIN	-	24	800PCS	15/Reel
2*15PIN	28.4	32	800PCS	11/Reel
2*20~2*25PIN	40.4	44	800PCS	8/Reel

- 包装说明:
- 把成品包入卷盘中, 每盘装800PCS, 卷盘上贴上合格证, 将装好产品的卷盘放进外箱中, 外箱内先套一个大PE袋, 外箱上贴贴上合格证.
 - 所有材料有害物控制需符合RoHS标准.

东莞市高迪电子有限公司
DONG GUAN GAO DI ELECTRONICS CO., LTD

TITLE:

PART NO.: A1008AWW 卷装规范

DWG NO.: GCBZ-0852

SCALE: 1 : 1

SHEET: 1 / 1

USE: CUSTOMER

APPD: 邵敬和

CHKD: 方松乐

DR: 蒋建银

UNITS: mm