

IP67

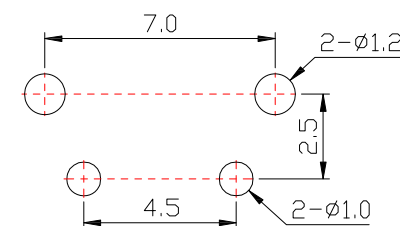
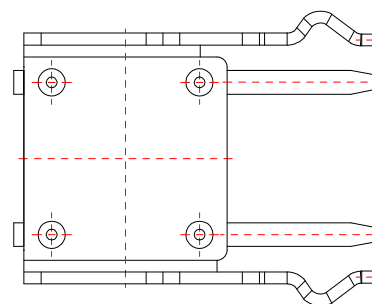
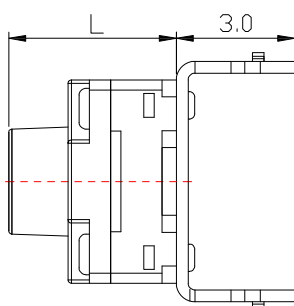
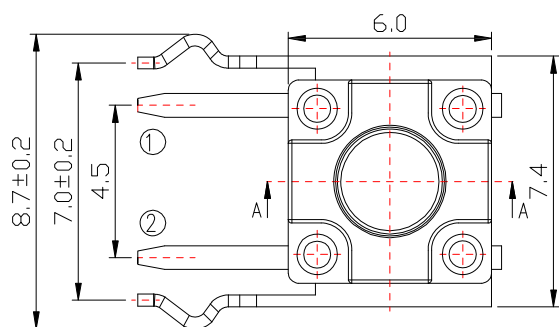

P.C.B MOUNTING PATTERN DIMENSION

SPECIFICATIONS

Rating	DC 12V 50mA Max.			
Contact Resistance	50mΩ Max.			
Travel	0.30 ± 0.10 mm			
Operating Force	2	180 ± 50gf	3	230 ± 50gf
Operating Life (cycles)	100,000			

8	WATERPROOF2	1	PE	/
7	WATERPROOF1	1	SILICONE RUBBER	WHITE
6	bracket	1	BRASS	PLATING Sn
5	SPRING	1	STAINLESS STEEL	PLATING SILVER
4	BUTTON	1	PA66	BLACK
3	COVER	1	PA66	BLACK
2	CONTACT	1	BRASS	PLATING SILVER
1	HOUSING	1	PPA	BLACK
ITEM	PART NAME	Q'TY/EA	MATERIAL	FINISH

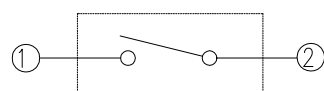
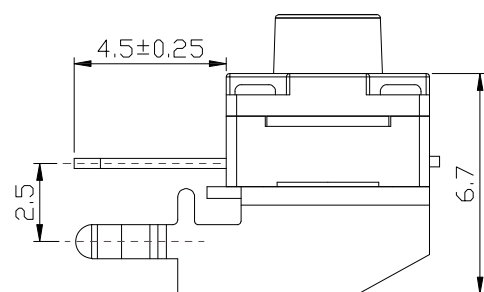

CIRCUIT DIAGRAM

MODEL NO.	TS-A20WV1	TS-A20WV1A	TS-A20WV1Q	TS-A20WV1QL	TS-A20WV1B	TS-A20WV1C	TS-A20WV1CL	TS-A20WV1DL	TS-A20WV1D	TS-A20WV1Y	TS-A20WV1W	TS-A20WV1WL	TS-A20WV1FL	TS-A20WV1K
L (mm)	4.30	5.00	6.00	6.50	7.00	8.00	8.50	9.00	9.50	10.00	11.00	11.50	12.00	13.00



TOLERANCE UNLESS OTHERWISE STATED:  
 Up to 5 ±0.2  
 Above 5 ~ 15 ±0.3  
 Above 15 ~ 30 ±0.4  
 Above 30 ~ 50 ±0.5  
 Angle ±0.3

3RD. ANGEL'S



UNITS MM

DRAWN BY: Jack Lu DATE: 06/29/21  
 CHECKED BY: Jacky Chen DATE: 06/29/21  
 APPROVED BY: Tony Kao DATE: 06/29/21

MAT'L		TITLE	SWITCH	
FINISH		MODLE	TACT SWITCH 90度 DIP 防水IP67	
SCALE	1 : 1	DWG NO.	TS-A20WV1x-x-S360	SIZE A4
SHEET NO.	1 of 1	PART NO.	TS-A20WV1x-x-S360	VER R

ITEM NO.	DESCRIPTION	DRAWN	DATE