

IPX7

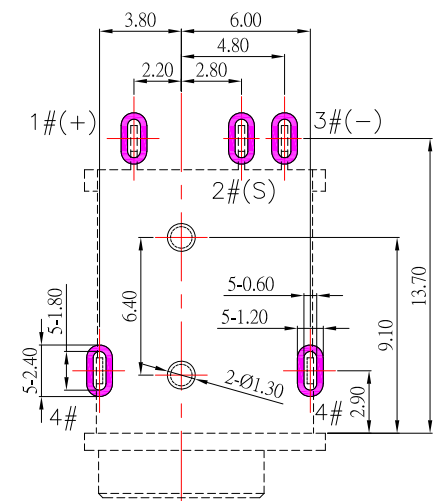
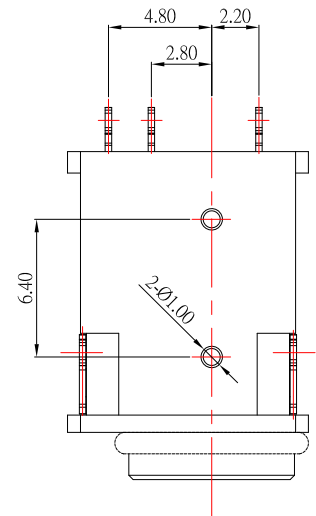
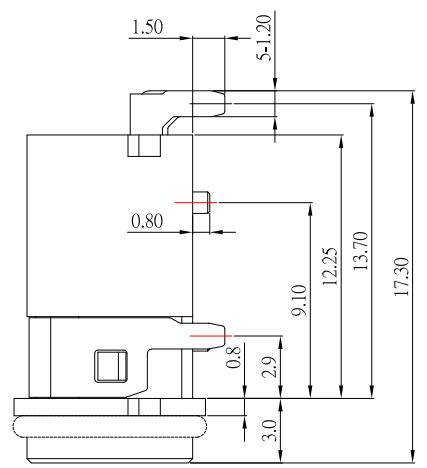
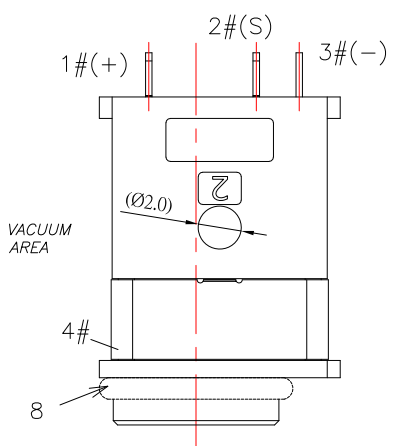
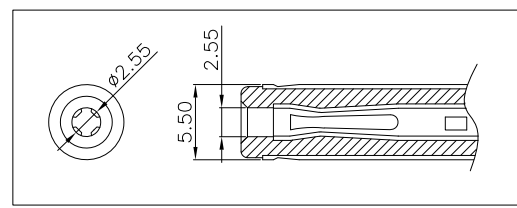
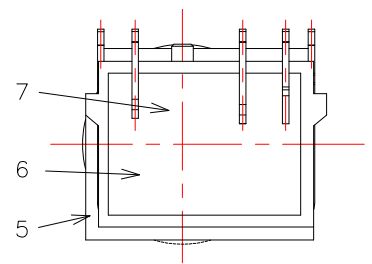

P.C.B LAYOUT

SPECIFICATION

- Rating : DC 48V , 5.0A
- Contact resistance : $\leq 50m\Omega$
- Insulation resistance : $\geq 100M\Omega$
- Withstand voltage : 500VAC
- Insertion and extraction force : 3-35N
- life test : 5,000 cycles

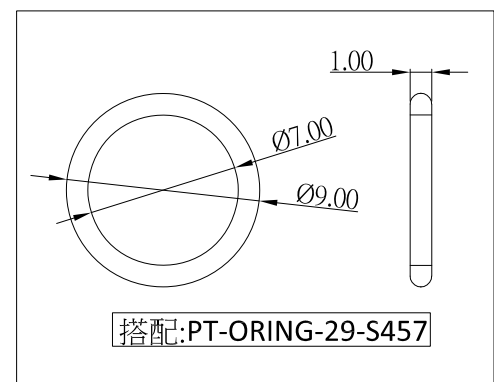
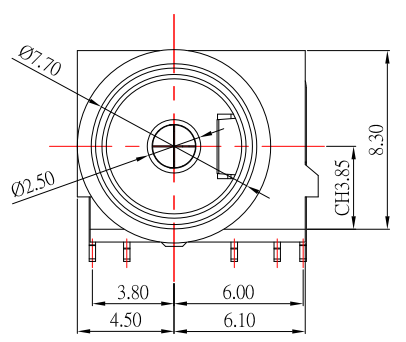
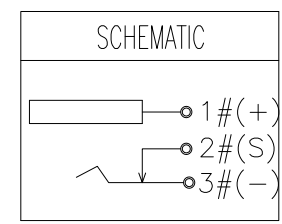

ITEM	NAME	Q'TY	DESCRIPTION
8	WATERPROOF RING	1	SILICONE; WHITE
7	GLUE	1	EPOXY; BLACK
6	BACK COVER	1	PA10T; BLACK
5	HOUSING	1	PA10T; BLACK
4	TERMINAL 4#	1	SUS; NICKEL PLATING
3	TERMINAL 3#	1	BRASS; NICKEL UNDERPLATING OVERALL, Au PLATING ON SOLDER AREA
2	TERMINAL 2#	1	PHOSPHOR BRONZE; NICKEL UNDERPLATING OVERALL, Au PLATING ON THE WHOLE
1	CENTER PIN	1	BRASS; NICKEL UNDERPLATING OVERALL, Au PLATING ON SOLDER AREA

東莞市高迪電子有限公司
DONG GUAN GAO DI ELECTRONICS CO., LTD

TOLERANCE UNLESS OTHERWISE STATED:
 Up to 5 ±0.2
 Above 5 ~ 15 ±0.3
 Above 15 ~ 30 ±0.4
 Above 30 ~ 50 ±0.5
 Angle ±0.3

3RD. ANGEL'S

UNITS MM

DRAWN BY:	DATE	MAT'L	TITLE	JACK
Jack Lu	07/02/24			
CHECKED BY:	DATE	FINISH	MODLE	防水 DC JACK
Jacky Chen	07/02/24			
APPROVED BY:	DATE	SCALE	DWG NO.	DC-WP3090CH-2.5-S457
Tony Kao	07/02/24	1 : 1		
		SHEET NO.	PART NO.	DC-WP3090CH-2.5-S457
		1 of 1		

1	更新Rating	Jack	070224
ITEM NO.	DESCRIPTION	DRAWN	DATE

SIZE A4
VER R1