

P.C.B LAYOUT
TOP VIEW

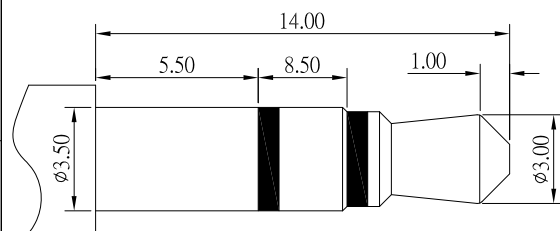

3.5mm 3 POLE PLUG

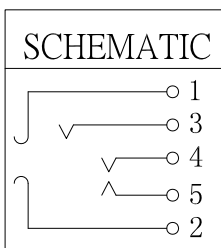
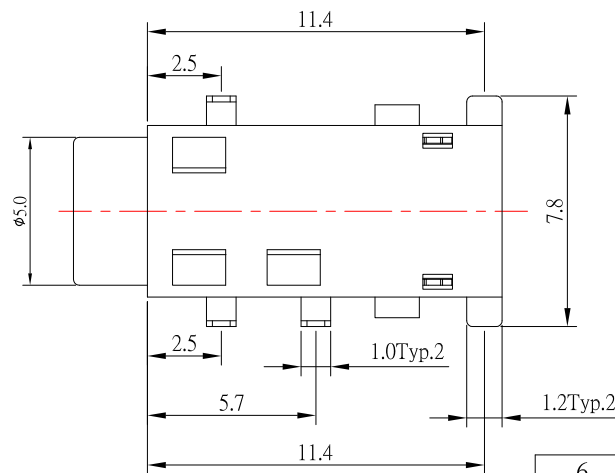

SPECIFICATION

- Rating: DC 30V 0.5A ;
- Contact resistance: $\leq 30m\Omega$;
- Insulation resistance: $\geq 100M\Omega$;
- Withstand voltage: 500VAC ;
- Insertion and extraction force: 3-20N;
- life test: 5,000 cycles °

NO.	DESCRIPTION	QTY	MATERIAL	PLATING
6	HOUSING	1	PA9T	
5	5# CONTACT FOOT	1	PHOSPHOR BRONZE	Au-Plating
4	4# CONTACT FOOT	1	PHOSPHOR BRONZE	Au-Plating
3	3# CONTACT FOOT	1	PHOSPHOR BRONZE	Au-Plating
2	2# CONTACT FOOT	1	PHOSPHOR BRONZE	Au-Plating
1	1# CONTACT FOOT	1	PHOSPHOR BRONZE	Au-Plating



TOLERANCE UNLESS OTHERWISE STATED:
 Up to 5 ±0.2
 Above 5 ~ 15 ±0.3
 Above 15 ~ 30 ±0.4
 Above 30 ~ 50 ±0.5
 Angle ±0.3

3RD. ANGEL'S

UNITS MM

DRAWN BY:	DATE	MAT'L	TITLE	JACK
Jack Lu	04/12/17			
CHECKED BY:	DATE	FINISH	MODLE	3.5mm PHONE JACK 端子腳鍍金
Jacky Chen	04/12/17			
APPROVED BY:	DATE	SCALE	DWG NO.	PJ-5055D-S124
Tony Kao	04/12/17	1 : 1		
		SHEET NO.	PART NO.	PJ-5055D-S124
		1 of 1		
				SIZE A4
				VER R1