

P.C.B LAYOUT
(TOP VIEW)

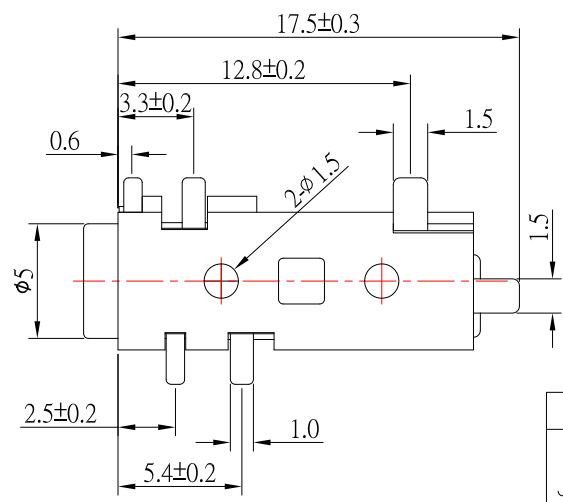

SCHEMATIC

PJ-3756	PJ-3755	PJ-3755A	PJ-3754	PJ-3755B	PJ-3753

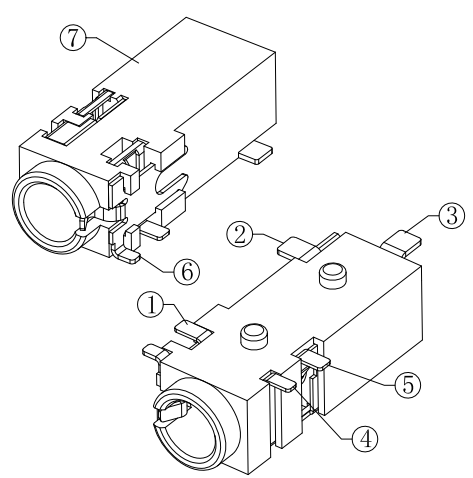
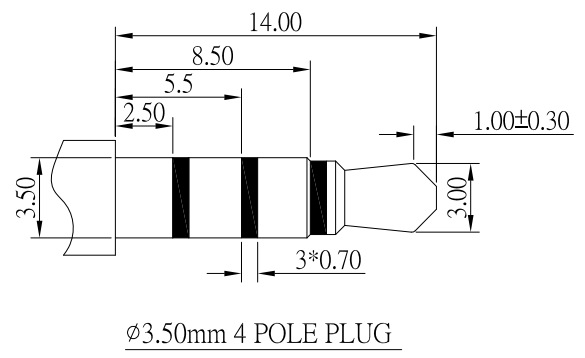

SPECIFICATION

- Rating : DC 30V 1.0A ;
- Contact resistance : ≤30mΩ ;
- Insulation resistance : ≥100MΩ ;
- Withstand voltage : 500VAC ;
- Insertion and extraction force : 3-20N;
- life test : 5,000 cycles .

NO.	DESCRIPTION	QTY	MATERIAL	PLATING
7	HOUSING	1	PA9T	
6	6# CONTACT FOOT	1	PHOSPHOR BRONZE	Ag-Plating
5	5# CONTACT FOOT	1	Be-Cu	Ag-Plating
4	4# CONTACT FOOT	1	PHOSPHOR BRONZE	Ag-Plating
3	3# CONTACT FOOT	1	BRASS	Ag-Plating
2	2# CONTACT FOOT	1	PHOSPHOR BRONZE	Ag-Plating
1	1# CONTACT FOOT	1	Be-Cu	Ag-Plating



TOLERANCE UNLESS OTHERWISE STATED :
 Up to 5 ±0.2
 Above 5 ~ 15 ±0.3
 Above 15 ~ 30 ±0.4
 Above 30 ~ 50 ±0.5
 Angle ±0.3

3RD. ANGEL'S

UNITS MM

DRAWN BY: Jack Lu	DATE: 05/07/19	MAT'L	TITLE: JACK
CHECKED BY: Jacky Chen	DATE: 05/07/19	FINISH	MODLE: PHONE JACK
APPROVED BY: Tony Kao	DATE: 05/07/19	SCALE: 1 : 1	DWG NO. PJ-375x-S124
		SHEET NO. 1 of 1	PART NO. PJ-375x-S124

ITEM NO.	DESCRIPTION	DRAWN	DATE
2	更新尺寸	Jack	050719
1	更新為A0版	Jack	030217

SIZE: A4
VER: R2