

P.C.B LAYOUT
TOP VIEW

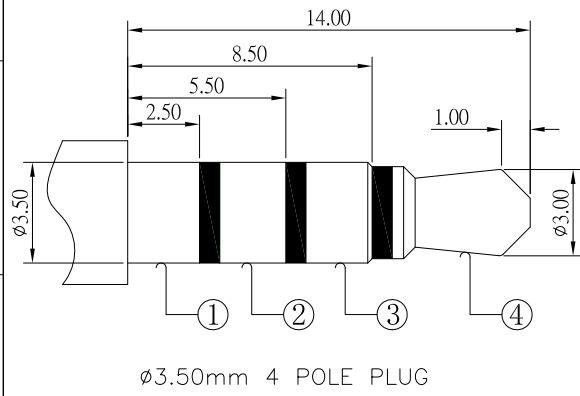

φ3.50mm 4 POLE PLUG

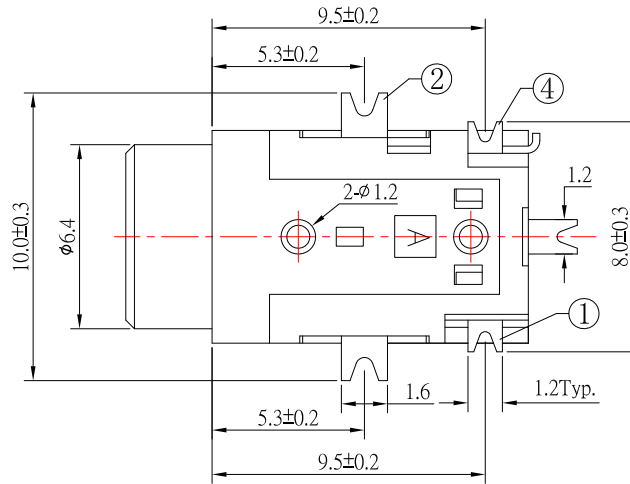

SCHEMATIC

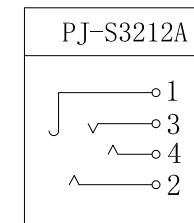

SPECIFICATION

1. Rating : DC 30V, 0.5A ;
2. Contact resistance : $\leq 30m\Omega$;
3. Insulation resistance : $\geq 100M\Omega$;
4. Withstand voltage : 500VAC ;
5. Insertion and extraction force : 3-30N;
6. life test : 5,000 cycles °

| NO. | DESCRIPTION | QTY | MATERIAL | PLATING |
|-----|-----------------|-----|-----------------|------------|
| ⑥ | BUSHING | 1 | BRASS | Au-Plating |
| ⑤ | HOUSING | 1 | PA9T | |
| ④ | 4# CONTACT FOOT | 1 | PHOSPHOR BRONZE | Au-Plating |
| ③ | 3# CONTACT FOOT | 1 | PHOSPHOR BRONZE | Au-Plating |
| ② | 2# CONTACT FOOT | 1 | PHOSPHOR BRONZE | Au-Plating |
| ① | 1# CONTACT FOOT | 1 | PHOSPHOR BRONZE | Au-Plating |



TOLERANCE UNLESS OTHERWISE STATED:
 Up to 5 ±0.2
 Above 5 ~ 15 ±0.3
 Above 15 ~ 30 ±0.4
 Above 30 ~ 50 ±0.5
 Angle ±0.3

3RD. ANGEL'S



UNITS

MM

| | | | | |
|--------------|----------|-----------|----------|----------------|
| DRAWN BY: | DATE | MAT'L | TITLE | JACK |
| Jack Lu | 06/22/20 | | | |
| CHECKED BY: | DATE | FINISH | MODLE | PHONE JACK |
| Jacky Chen | 06/22/20 | | | |
| APPROVED BY: | DATE | SCALE | DWG NO. | PJ-S3212A-S124 |
| Tony Kao | 06/22/20 | 1 : 1 | | |
| | | SHEET NO. | PART NO. | PJ-S3212A-S124 |
| | | 1 of 1 | | |
| | | | | SIZE A4 |
| | | | | VER R1 |

| ITEM NO. | DESCRIPTION | DRAWN | DATE |
|----------|-------------|-------|--------|
| 1 | 更新樣式 | Jack | 062220 |