

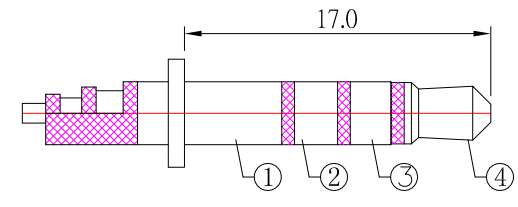

P.C.B LAYOUT  
TOP VIEW

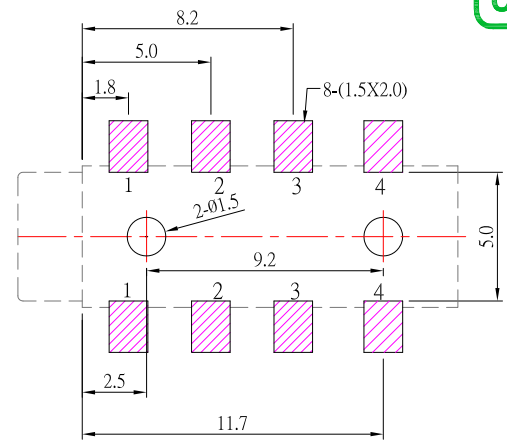

SCHEMATIC

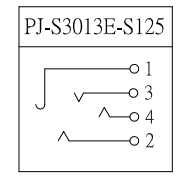

SPECIFICATION

- 1.Rating : DC 30V 0.5A
- 2.Contact resistance :  $\leq 50m\Omega$
- 3.Insulation resistance :  $\geq 100M\Omega$  (DC250V)
- 4.Withstand voltage : 500VAC
- 5.Insertion and extraction force : 3-20N
- 6.life test : 5,000 cycles

NO.	DESCRIPTION	QTY	MATERIAL	PLATING
⑤	HOUSING	1	PA9T	
④	CONTACT FOOT #4	1	STAINLESS STEEL	Ag-Plating
③	CONTACT FOOT #3	1	STAINLESS STEEL	Ag-Plating
②	CONTACT FOOT #2	1	STAINLESS STEEL	Ag-Plating
①	CONTACT FOOT #1	1	STAINLESS STEEL	Ag-Plating



TOLERANCE UNLESS OTHERWISE STATED :  
 Up to 5 ±0.2  
 Above 5 ~ 15 ±0.3  
 Above 15 ~ 30 ±0.4  
 Above 30 ~ 50 ±0.5  
 Angle ±0.3°

3RD. ANGEL'S

UNITS MM

DRAWN BY:	DATE	MAT'L	TITLE	JACK
Jack Lu	04/15/14			
CHECKED BY:	DATE	FINISH	MODLE	PHONE JACK
Jacky Chen	04/15/14			
APPROVED BY:	DATE	SCALE	DWG NO.	PJ-S3013E-S125
Tony Kao	04/15/14	1 : 1		
		SHEET NO.	PART NO.	PJ-S3013E-S125
		1 of 1		
			SIZE	A4
			VER	R2

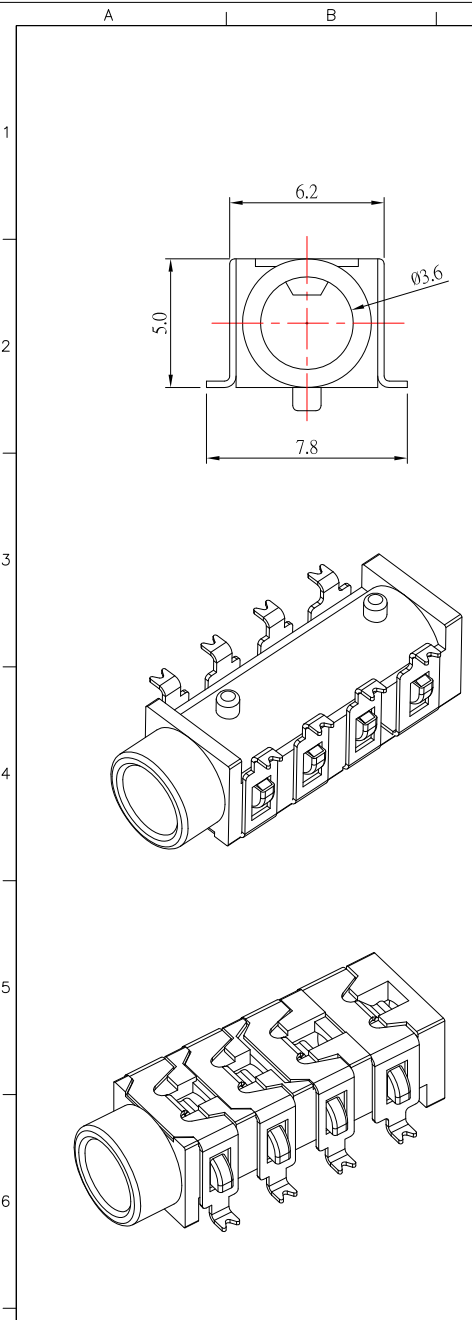

ITEM NO.	DESCRIPTION	DRAWN	DATE
2	更新SPEC及材質	Jack	041514
1	更新圖面	Jack	112312