

ø3.50mm 3 POLE PLUG

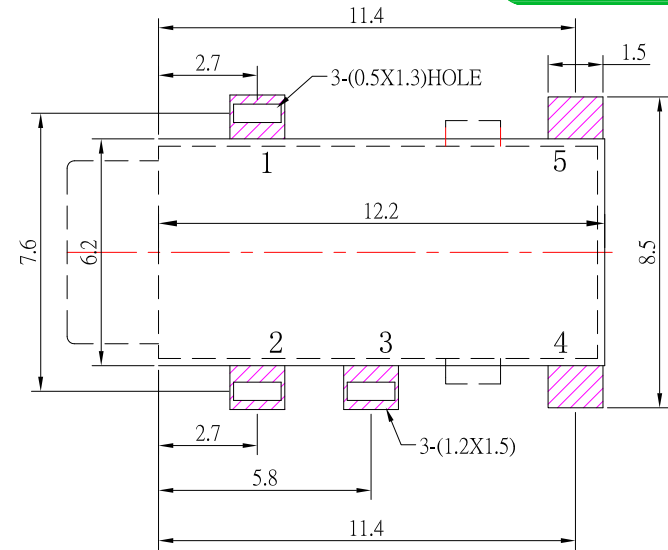

P.C.B LAYOUT
TOP VIEW

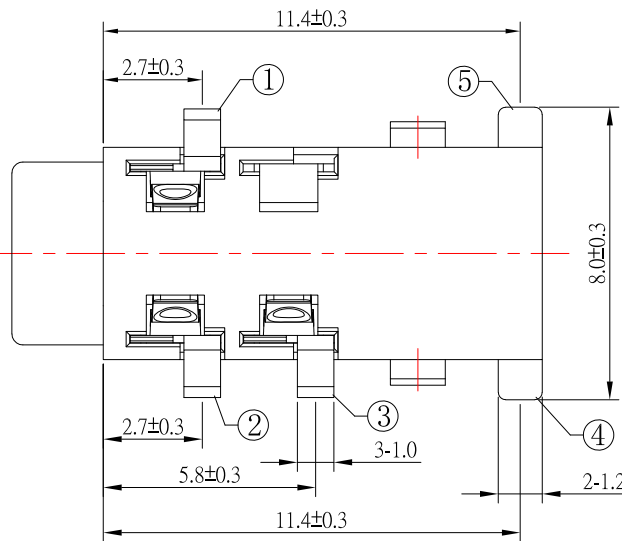
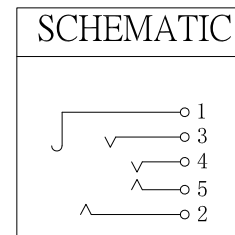
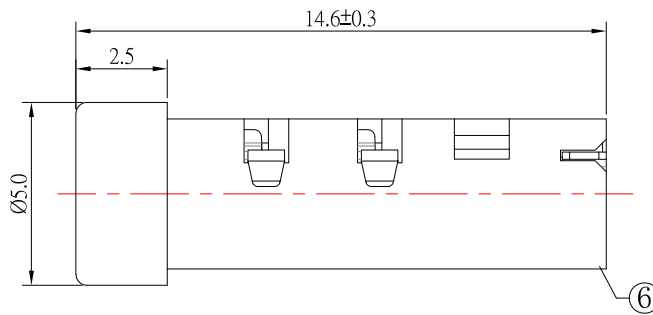
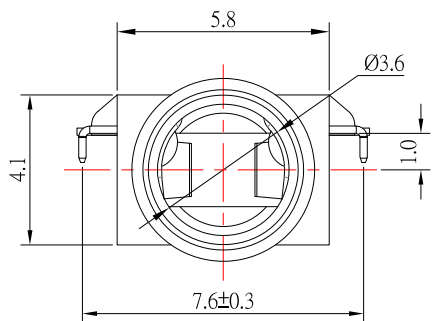

SPECIFICATION

- 1.Rating : DC 30V 0.5A ;
- 2.Contact resistance : $\leq 30m\Omega$;
- 3.Insulation resistance : $\geq 100M\Omega$;
- 4.Withstand voltage : 500VAC ;
- 5.Insertion and extraction force : 3-30N;
- 6.life test : 5,000 cycles °

NO.	DESCRIPTION	Q'TY	MATERIAL	PLATING
6	HOUSING	1	PA9T	
5	5# CONTACT FOOT	1	PHOSPHOR BRONZE	Au-Plating
4	4# CONTACT FOOT	1	PHOSPHOR BRONZE	Au-Plating
3	3# CONTACT FOOT	1	PHOSPHOR BRONZE	Au-Plating
2	2# CONTACT FOOT	1	PHOSPHOR BRONZE	Au-Plating
1	1# CONTACT FOOT	1	PHOSPHOR BRONZE	Au-Plating

ITEM NO.	DESCRIPTION	DRAWN	DATE
4	更新圖面	Jack	071024
3	更新樣式	Jack	082119
2	更新尺寸	Jack	080519
1	新增PLUG	Jack	121318

東莞市高迪電子有限公司
DONG GUAN GAO DI ELECTRONICS CO., LTD

TOLERANCE UNLESS OTHERWISE STATED :

Up to 5	±0.2
Above 5 ~ 15	±0.3
Above 15 ~ 30	±0.4
Above 30 ~ 50	±0.5
Angle	±0.3°

3RD. ANGEL'S

UNITS MM

DRAWN BY:	DATE	MAT'L	TITLE	JACK
Jack Lu	07/10/24		MODLE	PHONE JACK
CHECKED BY:	DATE	FINISH	SCALE	DWG NO.
Jacky Chen	07/10/24		1 : 1	PJ-S3112A1-S124
APPROVED BY:	DATE	SHEET NO.	PART NO.	SIZE
Tony Kao	07/10/24	1 of 1	PJ-S3112A1-S124	A4
				VER
				R4