

P.C.B LAYOUT
TOP VIEW

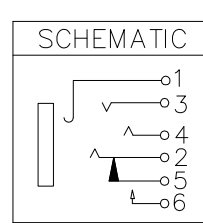

SPECIFICATION

1. Rating : DC 30V , 1.0A ;
2. Contact resistance : ≤ 30mΩ ;
3. Insulation resistance : ≥ 100MΩ ;
4. Withstand voltage : 500VAC ;
5. Insertion and extraction force : 3-30N;
6. Life test : 5,000 cycles .

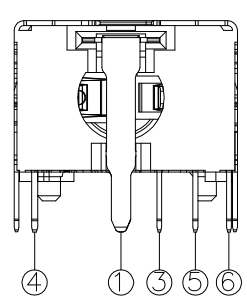
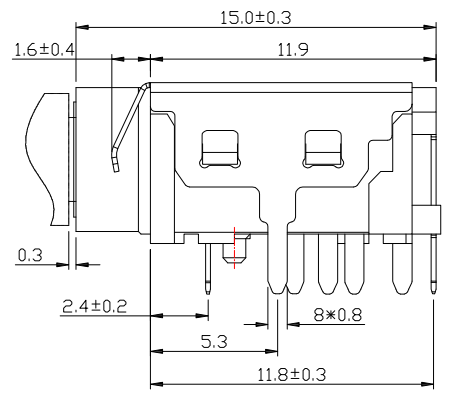
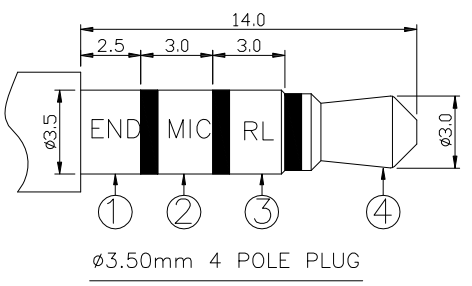
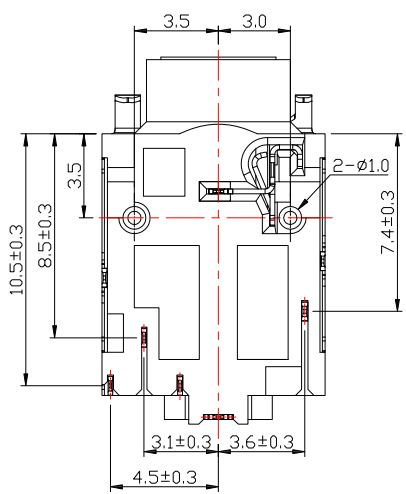
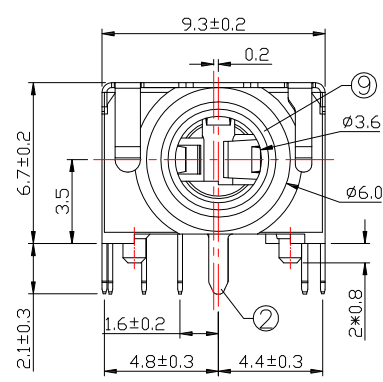

No	PART NAME	QTY	MATERIAL	REMARK
⑨	RING	1	BRASS	Ni-Plating
⑧	SHELL	1	SUS	Ni-Plating
⑦	HOUSING	1	PA9T	
⑥	CONTACT FOOT	1	PHOSPHOR BRONZE	Au-Plating
⑤	SPRING PIECE	1	PHOSPHOR BRONZE	Au-Plating
④	CURVE PIECE	1	PHOSPHOR BRONZE	Au-Plating
③	SPRING PIECE	1	PHOSPHOR BRONZE	Au-Plating
②	SPRING PIECE	1	PHOSPHOR BRONZE	Au-Plating
①	CONTACT FOOT	1	PHOSPHOR BRONZE	Au-Plating



TOLERANCE UNLESS OTHERWISE STATED:
 Up to 5 ±0.2
 Above 5 ~ 15 ±0.3
 Above 15 ~ 30 ±0.4
 Above 30 ~ 50 ±0.5
 Angle ±0.3

3RD. ANGEL'S

UNITS MM

DRAWN BY:	DATE	MAT'L	TITLE	JACK
Jack Lu	08/27/21			
CHECKED BY:	DATE	FINISH	MODLE	PHONE JACK
Jacky Chen	08/27/21			
APPROVED BY:	DATE	SCALE	DWG NO.	PJ-D3242K-S124
Tony Kao	08/27/21	1 : 1	PART NO.	PJ-D3242K-S124
		SHEET NO.	1 of 1	
				SIZE A4
				VER R

ITEM NO.	DESCRIPTION	DRAWN	DATE