

SPECIFICATION

1. Rating : DC 30V 1.0A ;
2. Contact resistance : $\leq 50m\Omega$;
3. Insulation resistance : $\geq 100M\Omega$ (DC250V) ;
4. Withstand voltage : 250VAC ;
5. Insertion and extraction force : 3-20N;
6. life test : 5,000 cycles °

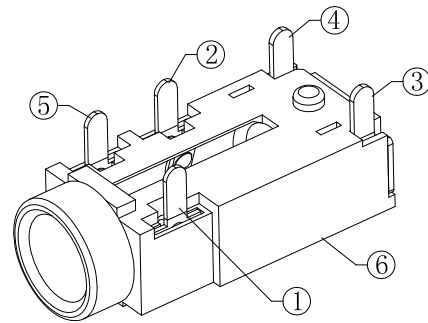
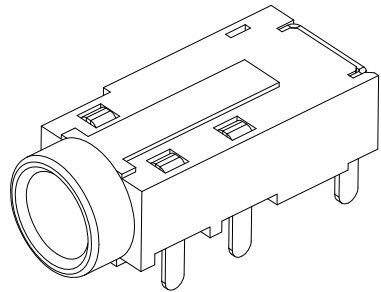

NO.	DESCRIPTION	QTY	MATERIAL	PLATING
6	HOUSING	1	PBT	
5	5# CONTACT FOOT	1	PHOSPHOR BRONZE	Ag-Plating
4	4# CONTACT FOOT	1	BRASS	Ag-Plating
3	3# CONTACT FOOT	1	SUS301	Ag-Plating
2	2# CONTACT FOOT	1	PHOSPHOR BRONZE	Ag-Plating
1	1# CONTACT FOOT	1	PHOSPHOR BRONZE	Ag-Plating

東莞市高迪電子有限公司
DONG GUAN GAO DI ELECTRONICS CO., LTD

TOLERANCE UNLESS OTHERWISE STATED :
 Up to 5 ±0.2
 Above 5 ~ 15 ±0.3
 Above 15 ~ 30 ±0.4
 Above 30 ~ 50 ±0.5
 Angle ±0.3°

3RD. ANGEL'S

UNITS MM

DRAWN BY:	DATE	MAT'L	TITLE	JACK
Jack Lu	09/16/14			
CHECKED BY:	DATE	FINISH	MODLE	PHONE JACK
Jacky Chen	09/16/14			
APPROVED BY:	DATE	SCALE	DWG NO.	PJ-D3081A-S125
Tony Kao	09/16/14	1 : 1		
		SHEET NO.	PART NO.	PJ-D3081A-S125
		1 of 1		
				SIZE A4
				VER R1