

P.C.B LAYOUT
TOP VIEW

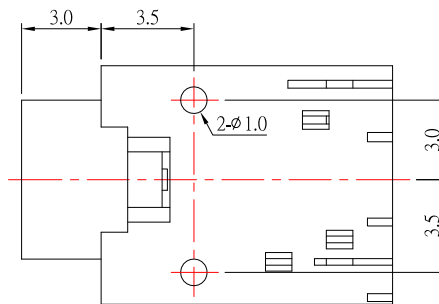
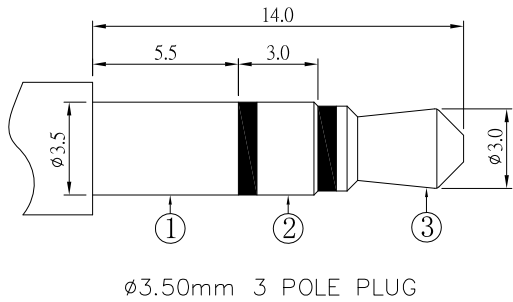

SPECIFICATION

1. Rating : DC 30V, 1.0A
2. Contact resistance : $\leq 30m\Omega$
3. Insulation resistance : $\geq 100M\Omega$
4. Withstand voltage : 250VAC
5. Insertion and extraction force : 3-20N
6. Life test : 5,000 cycles

SCHMATIC

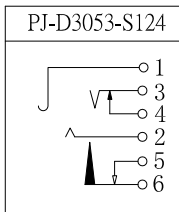

NO.	DESCRIPTION	QTY	MATERIAL	PLATING
7	HOUSING	1	PBT	
6	CONTACT FOOT	1	PHOSPHOR BRONZE	Ag-Plating
5	SPRING PIECE	1	PHOSPHOR BRONZE	Ag-Plating
4	CURVE PIECE	1	PHOSPHOR BRONZE	Ag-Plating
3	SPRING PIECE	1	PHOSPHOR BRONZE	Ag-Plating
2	SPRING PIECE	1	PHOSPHOR BRONZE	Ag-Plating
1	CONTACT FOOT	1	PHOSPHOR BRONZE	Ag-Plating

東莞市高迪電子有限公司
DONG GUAN GAO DI ELECTRONICS CO., LTD

TOLERANCE UNLESS OTHERWISE STATED :
 Up to 5 ±0.2
 Above 5 ~ 15 ±0.3
 Above 15 ~ 30 ±0.4
 Above 30 ~ 50 ±0.5
 Angle ±0.3°

3RD. ANGEL'S

UNITS MM

DRAWN BY:	DATE	MAT'L	TITLE	JACK
Jack Lu	04/25/24			
CHECKED BY:	DATE	FINISH	MODLE	PHONE JACK 常閉型 / 無外殼
Jacky Chen	04/25/24			
APPROVED BY:	DATE	SCALE	DWG NO.	PJ-D3053-S124
Tony Kao	04/25/24	1 : 1		
		SHEET NO.	PART NO.	PJ-D3053-S124
		1 of 1		
				SIZE A4
				VER R2

ITEM NO.	DESCRIPTION	DRAWN	DATE
2	更新圖面	Jack	042524
1	更新外型樣式	Jack	100719