

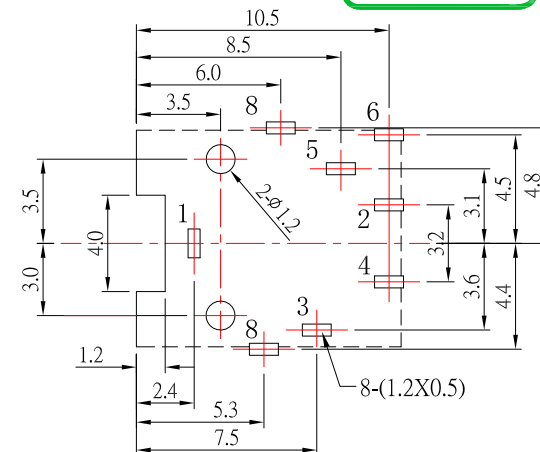

PJ-D30353FS-x-S457

Blank	Black
PI	Pink
GR	Green

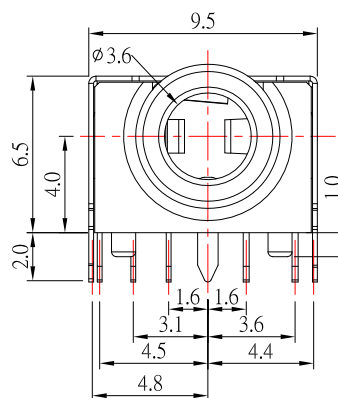
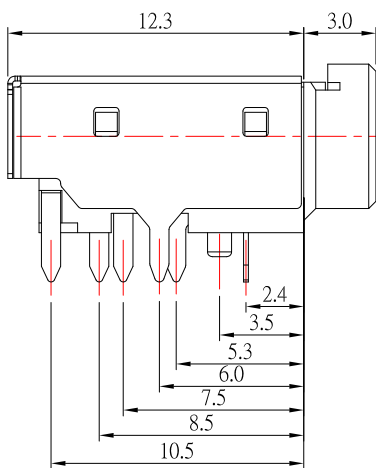
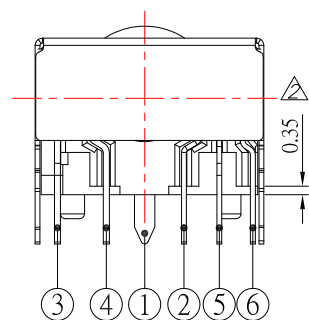
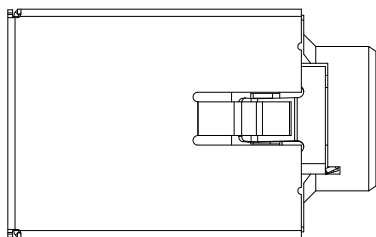

P.C.B LAYOUT
TOP VIEW

SPECIFICATION

1. Rating : DC 30V, 0.5A ;
2. Contact resistance : $\leq 30m\Omega$;
3. Insulation resistance : $\geq 100M\Omega$;
4. Withstand voltage : 500VAC ;
5. Insertion and extraction force : 3-30N;
6. life test : 5,000 cycles °

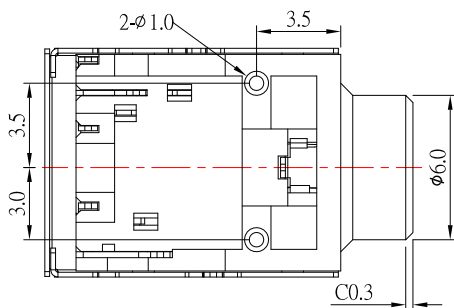
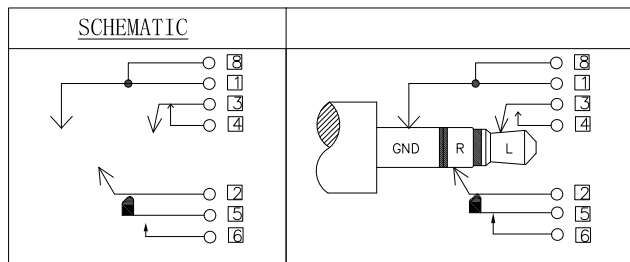

NO.	DESCRIPTION	QTY	MATERIAL	PLATING
8	SHELL	1	SUS	Ni Plating
7	HOUSING	1	PA9T	
6	CONTACT FOOT	1	PHOSPHOR BRONZE	Sn Plated over Ni
5	SPRING PIECE	1	PHOSPHOR BRONZE	Sn Plated over Ni
4	CURVE PIECE	1	PHOSPHOR BRONZE	Sn Plated over Ni
3	SPRING PIECE	1	PHOSPHOR BRONZE	Sn Plated over Ni
2	SPRING PIECE	1	PHOSPHOR BRONZE	Sn Plated over Ni
1	CONTACT FOOT	1	PHOSPHOR BRONZE	Sn Plated over Ni

東莞市高迪電子有限公司
DONG GUAN GAO DI ELECTRONICS CO., LTD

TOLERANCE UNLESS OTHERWISE STATED:
 Up to 5 ±0.2
 Above 5 ~ 15 ±0.3
 Above 15 ~ 30 ±0.4
 Above 30 ~ 50 ±0.5
 Angle ±0.3

3RD. ANGEL'S

UNITS MM

DRAWN BY:	DATE	MAT'L	TITLE	JACK
Jack Lu	09/19/23			
CHECKED BY:	DATE	FINISH	MODLE	PHONE JACK
Jacky Chen	09/19/23			
APPROVED BY:	DATE	SCALE	DWG NO.	PJ-D30353FS-x-S457
Tony Kao	09/19/23	1 : 1		
		SHEET NO.	PART NO.	PJ-D30353FS-x-S457
		1 of 1		

ITEM NO.	DESCRIPTION	DRAWN	DATE