

P.C.B LAYOUT  
TOP VIEW

SCHEMATIC

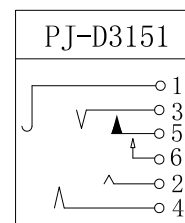

SPECIFICATION

1. Rating : DC 30V, 1.0A ;
2. Contact resistance :  $\leq 30m\Omega$  ;
3. Insulation resistance :  $\geq 100M\Omega$  ;
4. Withstand voltage : 500VAC ;
5. Insertion and extraction force : 3-30N;
6. life test : 5,000 cycles °

No	PART NAME	QTY	MATERIAL	REMARK
9	HOUSING	1	PA9T	
8	INSULATOR	1	PA9T	
7	SHELL	1	SUS	Ni-Plating
6	CONTACT FOOT	1	PHOSPHOR BRONZE	Au-Plating
5	CONTACT FOOT	1	PHOSPHOR BRONZE	Au-Plating
4	CONTACT FOOT	1	PHOSPHOR BRONZE	Au-Plating
3	CONTACT FOOT	1	PHOSPHOR BRONZE	Au-Plating
2	CONTACT FOOT	1	PHOSPHOR BRONZE	Au-Plating
1	CONTACT FOOT	1	PHOSPHOR BRONZE	Au-Plating

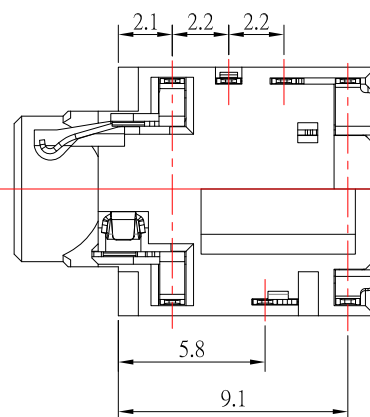
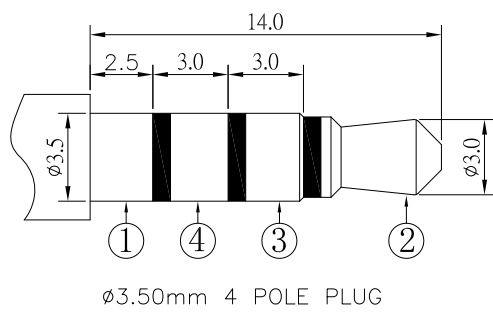
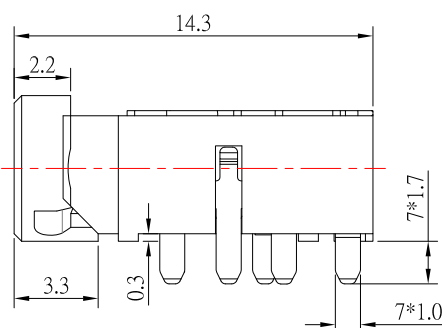
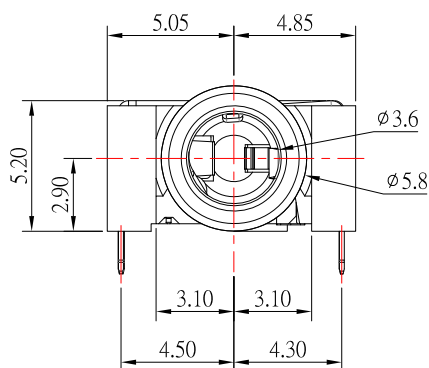

東莞市高迪電子有限公司  
DONG GUAN GAO DI ELECTRONICS CO., LTD

TOLERANCE UNLESS OTHERWISE STATED:  
 Up to 5 ±0.2  
 Above 5 ~ 15 ±0.3  
 Above 15 ~ 30 ±0.4  
 Above 30 ~ 50 ±0.5  
 Angle ±0.3°

3RD. ANGEL'S

UNITS MM

DRAWN BY:	DATE	MAT'L	TITLE	JACK
Jack Lu	08/10/20			
CHECKED BY:	DATE	FINISH	MODLE	PHONE JACK
Jacky Chen	08/10/20			
APPROVED BY:	DATE	SCALE	DWG NO.	PJ-D3151-S124
Tony Kao	08/10/20	1 : 1		
		SHEET NO.	PART NO.	PJ-D3151-S124
		1 of 1		
				SIZE A4
				VER R

ITEM NO.	DESCRIPTION	DRAWN	DATE