

P.C.B LAYOUT
TOP VIEW

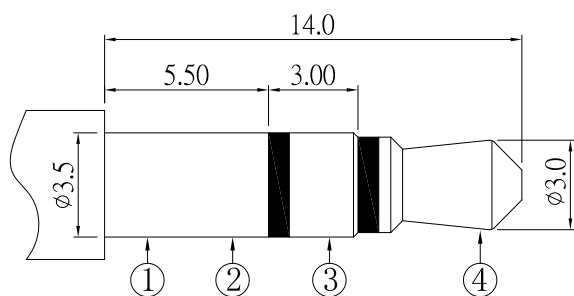

Ø3.50mm 3 POLE PLUG

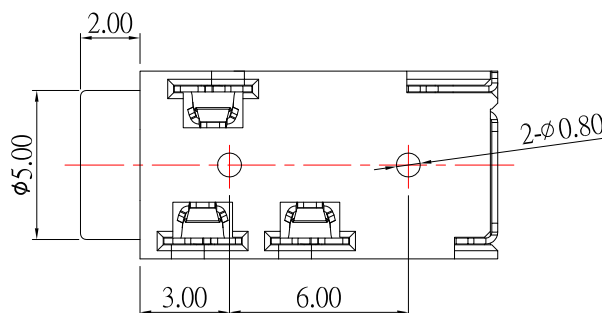

SPECIFICATION

1. Rating : DC 30V 0.5A ;
2. Contact resistance : $\leq 30m\Omega$;
3. Insulation resistance : $\geq 100M\Omega$;
4. Withstand voltage : 500VAC ;
5. Insertion and extraction force : 3-30N;
6. life test : 5,000 cycles °

SCHMATIC

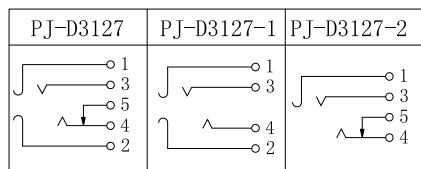

6	HOUSING	1	PA9T	
5	5# CONTACT FOOT	1	PHOSPHOR BRONZE	Ag-Plating
4	4# CONTACT FOOT	1	PHOSPHOR BRONZE	Ag-Plating
3	3# CONTACT FOOT	1	PHOSPHOR BRONZE	Ag-Plating
2	2# CONTACT FOOT	1	PHOSPHOR BRONZE	Ag-Plating
1	1# CONTACT FOOT	1	PHOSPHOR BRONZE	Ag-Plating
No	PART NAME	QTY	MATERIAL	REMARK



TOLERANCE UNLESS OTHERWISE STATED

Up to 5 ±0.2
Above 5 ~ 15 ±0.3
Above 15 ~ 30 ±0.4
Above 30 ~ 50 ±0.5
Angle ±0.3°

3RD. ANGEL'S



UNITS

MM

DRAWN BY:	DATE	MAT'L	TITLE	JACK
Jack Lu	10/31/22		MODLE	PHONE JACK
CHECKED BY:	DATE	SCALE	DWG NO.	PJ-D3127-x-S124
Jacky Chen	10/31/22	1 : 1	PART NO.	PJ-D3127-x-S124
APPROVED BY:	DATE	SHEET NO.	1 of 1	SIZE A4
Tony Kao	10/31/22			VER R2

2	更新圖面	Jack	103122
1	更新為A0版	Jack	090117
ITEM NO	DESCRIPTION	DRAWN	DATE