

P.C.B LAYOUT
TOP VIEW

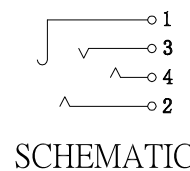
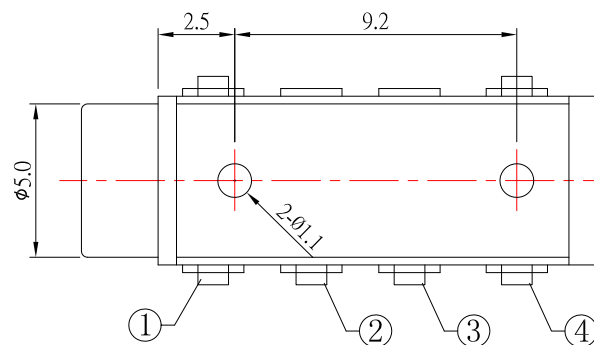
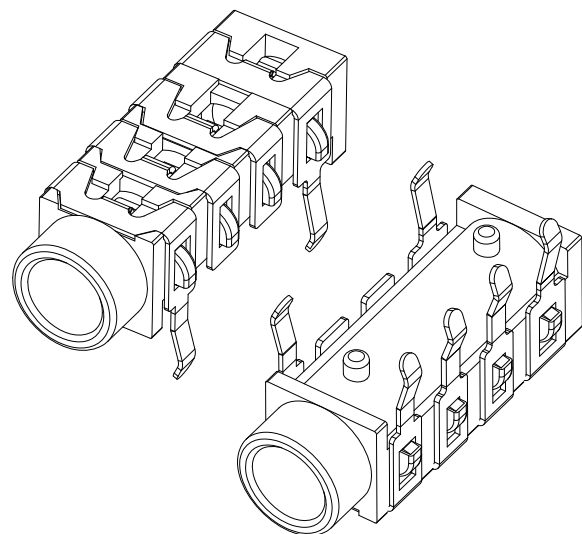

SCHEMATIC

SPECIFICATION

1. Rating : DC 30V 1.0A
2. Contact resistance : $\leq 30m\Omega$
3. Insulation resistance : $\geq 100M\Omega$
4. Withstand voltage : 500VAC
5. Insertion and extraction force : 3-20N
6. Life test : 5,000 cycles

5	HOUSING	1	PBT	
4	CONTACT FOOT	1	SUS301	Sn-Plating
3	CONTACT FOOT	1	SUS301	Sn-Plating
2	CONTACT FOOT	1	SUS301	Sn-Plating
1	CONTACT FOOT	1	SUS301	Sn-Plating
NO.	DESCRIPTION	QTY	MATERIAL	PLATING

東莞市高迪電子有限公司
DONG GUAN GAO DI ELECTRONICS CO., LTD

TOLERANCE UNLESS OTHERWISE STATED :
 Up to 5 ±0.2
 Above 5 ~ 15 ±0.3
 Above 15 ~ 30 ±0.4
 Above 30 ~ 50 ±0.5
 Angle ±0.3

3RD. ANGEL'S UNITS MM

DRAWN BY:	DATE	MAT'L	TITLE	JACK
Jack Lu	06/26/14		MODLE	PHONE JACK
CHECKED BY:	DATE	FINISH	SCALE	1 : 1
Jacky Chen	06/26/14		DWG NO.	PJ-D3013B-S125
APPROVED BY:	DATE	SHEET NO.	PART NO.	PJ-D3013B-S125
Tony Kao	06/26/14	1 of 1		

ITEM NO.	DESCRIPTION	DRAWN	DATE

7

7

A B C D E F G H I J