

P.C.B LAYOUT
TOP VIEW

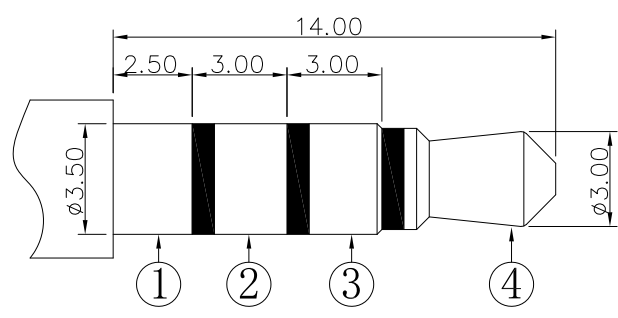

Ø3.50mm 4 POLE PLUG

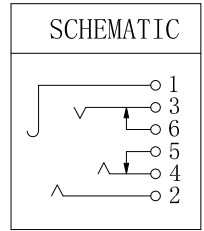
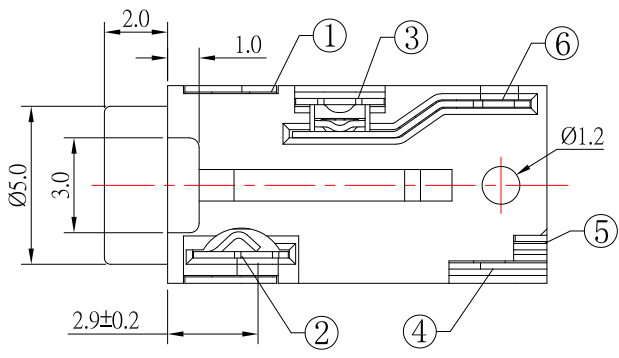

SPECIFICATION

- 1.Rating : DC 30V, 1.0A ;
- 2.Contact resistance : ≤30mΩ ;
- 3.Insulation resistance : ≥100MΩ ;
- 4.Withstand voltage : 500VAC ;
- 5.Insertion and extraction force : 3-30N;
- 6.life test : 5,000 cycles .

7	HOUSING	1	PA9T	
6	6# CONTACT FOOT	1	PHOSPHOR BRONZE	Au-Plating
5	5# CONTACT FOOT	1	PHOSPHOR BRONZE	Au-Plating
4	4# CONTACT FOOT	1	PHOSPHOR BRONZE	Au-Plating
3	3# CONTACT FOOT	1	PHOSPHOR BRONZE	Au-Plating
2	2# CONTACT FOOT	1	PHOSPHOR BRONZE	Au-Plating
1	1# CONTACT FOOT	1	PHOSPHOR BRONZE	Au-Plating
NO.	DESCRIPTION	QTY	MATERIAL	PLATING

9	更新尺寸及材質	Jack	091324
8	更新SCHEMATIC選項	Jack	032222
7	更新尺寸及材質	Jack	061219
6	更新SCHEMATIC選項	Jack	041819
ITEM NO.	DESCRIPTION	DRAWN	DATE

東莞市高迪電子有限公司
DONG GUAN GAO DI ELECTRONICS CO., LTD

TOLERANCE UNLESS OTHERWISE STATED :
 Up to 5 ±0.2
 Above 5 ~ 15 ±0.3
 Above 15 ~ 30 ±0.4
 Above 30 ~ 50 ±0.5
 Angle ±0.3

3RD. ANGEL'S

UNITS MM

DRAWN BY:	DATE	MAT'L	TITLE	JACK
Jack Lu	09/13/24			
CHECKED BY:	DATE	FINISH	MODLE	PHONE JACK
Jacky Chen	09/13/24			
APPROVED BY:	DATE	SCALE	DWG NO.	PJ-3956-S124
Tony Kao	09/13/24	1 : 1		
SHEET NO.	1 of 1	PART NO.	PJ-3956-S124	
				SIZE A4
				VER R9