

P.C.B LAYOUT  
(TOP VIEW)

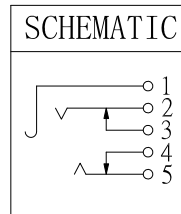
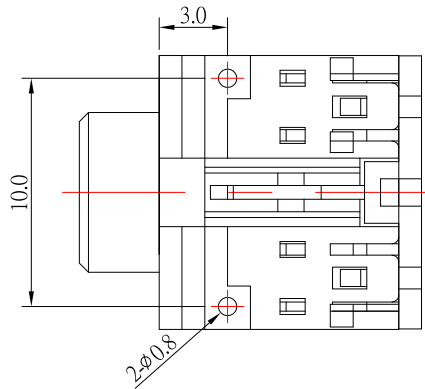
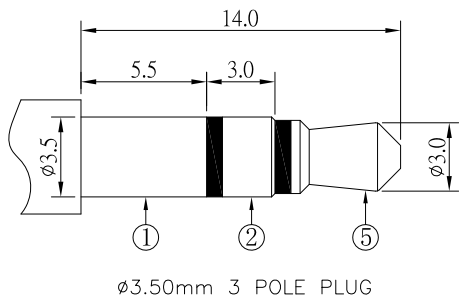

**SPECIFICATION**

1. Rating : DC 30V, 1.0A ;
2. Contact resistance : ≤ 30mΩ ;
3. Insulation resistance : ≥ 100MΩ ;
4. Withstand voltage : 500VAC ;
5. Insertion and extraction force : 3-30N
6. life test : 5,000 cycles .

NO.	DESCRIPTION	QTY	MATERIAL	PLATING
7	COVER	1	PBT	
6	HOUSING	1	PBT	
5	5# CONTACT FOOT	1	PHOSPHOR BRONZE	Sn-Plating
4	4# CONTACT FOOT	1	BRASS	Sn-Plating
3	3# CONTACT FOOT	1	BRASS	Sn-Plating
2	2# CONTACT FOOT	1	PHOSPHOR BRONZE	Sn-Plating
1	1# CONTACT FOOT	1	BRASS	Sn-Plating

ITEM NO.	DESCRIPTION	DRAWN	DATE
7	更新圖面	Jack	022324
6	更新樣式及尺寸	Jack	112922
5	更新樣式及尺寸	Jack	072121
4	更新樣式及尺寸公差	Jack	070821
3	更新樣式	Jack	090518
2	更新為AO版	Jack	011017
1	更新SPEC	Jack	122916

**東莞市高迪電子有限公司**  
DONG GUAN GAO DI ELECTRONICS CO., LTD

TOLERANCE UNLESS OTHERWISE STATED :

Up to 5 ±0.2  
Above 5 ~ 15 ±0.3  
Above 15 ~ 30 ±0.4  
Above 30 ~ 50 ±0.5  
Angle ±0.3

3RD. ANGEL'S



UNITS MM

DRAWN BY:	DATE	MAT'L	TITLE	JACK
Jack Lu	02/22/24			
CHECKED BY:	DATE	FINISH	MODLE	PHONE JACK
Jacky Chen	02/22/24			
APPROVED BY:	DATE	SCALE	DWG NO.	PJ-3565-S124
Tony Kao	02/22/24	1 : 1		
		SHEET NO.	PART NO.	PJ-3565-S124
		1 of 1		
				SIZE A4
				VER R7