

P.C.B LAYOUT MOUNTING PATTERN (TOP VIEW)

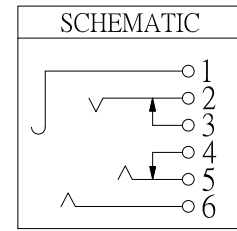

SPECIFICATION

- 1.Rating: DC 30V, 1.0A
- 2.Contact resistance: ≤50mΩ
- 3.Insulation resistance: ≥100MΩ
- 4.Withstand voltage: 500VAC
- 5.Insertion and extraction force: 3-20N
- 6.life test: 5,000 cycles

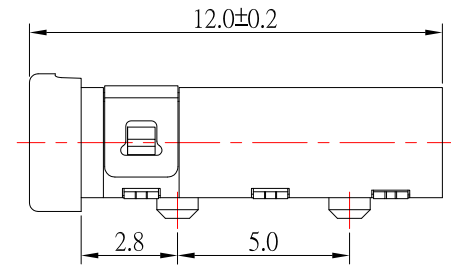
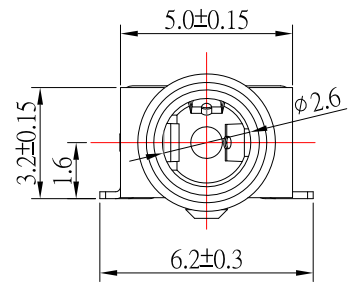
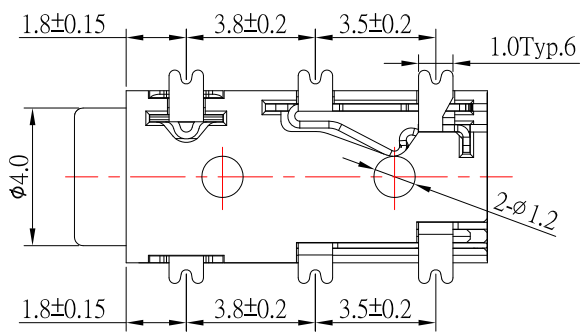
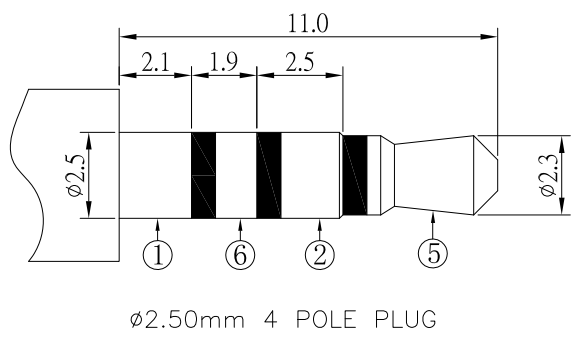

⑦	HOUSING	1	PA9T	
⑥	CONTACT FOOT #6	1	Phosphor Bronze	Au Plated over Ni
⑤	CONTACT FOOT #5	1	Phosphor Bronze	Au Plated over Ni
④	CONTACT FOOT #4	1	Phosphor Bronze	Au Plated over Ni
③	CONTACT FOOT #3	1	Phosphor Bronze	Au Plated over Ni
②	CONTACT FOOT #2	1	Phosphor Bronze	Au Plated over Ni
①	CONTACT FOOT #1	1	Phosphor Bronze	Au Plated over Ni
NO.	DESCRIPTION	QTY	MATERIAL	REMARK



TOLERANCE UNLESS OTHERWISE STATED:
 Up to 5 ±0.2
 Above 5 ~ 15 ±0.3
 Above 15 ~ 30 ±0.4
 Above 30 ~ 50 ±0.5
 Angle ±0.3°

3RD. ANGEL'S

UNITS MM

DRAWN BY:	DATE	MAT'L	TITLE	JACK
Jack Lu	10/26/21			
CHECKED BY:	DATE	FINISH	MODLE	PHONE JACK
Jacky Chen	10/26/21			
APPROVED BY:	DATE	SCALE	DWG NO.	PJ-2866D-H3-S124
Tony Kao	10/26/21	1 : 1		
		SHEET NO.	PART NO.	PJ-2866D-H3-S124
		1 of 1		
				SIZE A4
				VER R2

2	更新鍍層	Jack	102621
1	更新圖面	Jack	010821
ITEM NO.	DESCRIPTION	DRAWN	DATE