

P.C.B LAYOUT MOUNTING PATTERN  
(TOP VIEW)

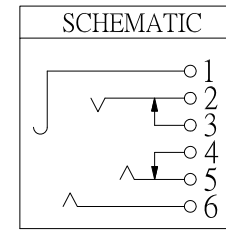

**SPECIFICATION**

- 1.Rating: DC 30V, 1.0A
- 2.Contact resistance:  $\leq 50m\Omega$
- 3.Insulation resistance:  $\geq 100M\Omega$
- 4.Withstand voltage: 500VAC
- 5.Insertion and extraction force: 3-20N
- 6.life test: 5,000 cycles

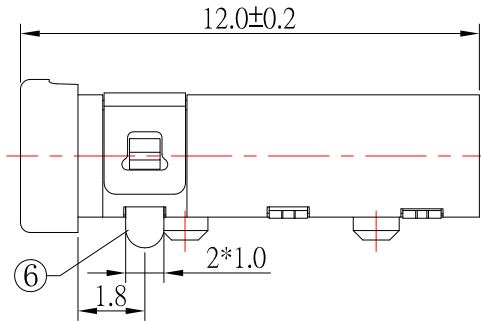
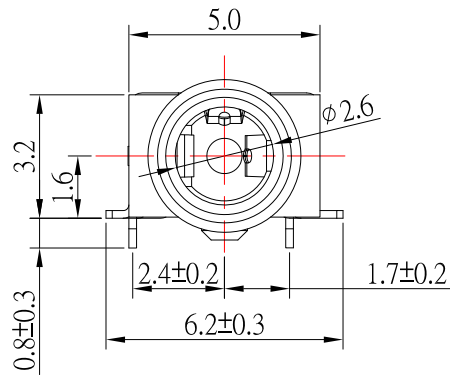
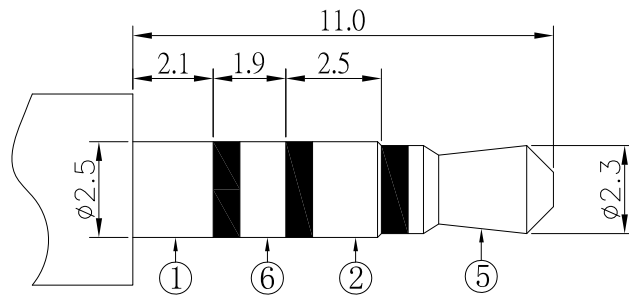

$\phi 2.50mm$  4 POLE PLUG

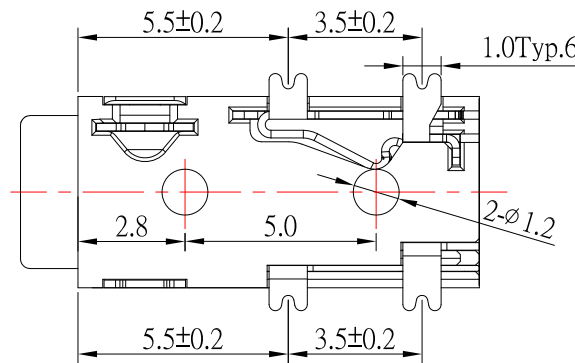

NO.	DESCRIPTION	QTY	MATERIAL	REMARK
⑦	HOUSING	1	PA9T	
⑥	CONTACT FOOT #6	1	Phosphor Bronze	Au-Plated
⑤	CONTACT FOOT #5	1	Phosphor Bronze	Au-Plated
④	CONTACT FOOT #4	1	Phosphor Bronze	Au-Plated
③	CONTACT FOOT #3	1	Phosphor Bronze	Au-Plated
②	CONTACT FOOT #2	1	Phosphor Bronze	Au-Plated
①	CONTACT FOOT #1	1	Phosphor Bronze	Au-Plated

東莞市高迪電子有限公司  
DONG GUAN GAO DI ELECTRONICS CO., LTD

TOLERANCE UNLESS OTHERWISE STATED:  
Up to 5 ±0.2  
Above 5 ~ 15 ±0.3  
Above 15 ~ 30 ±0.4  
Above 30 ~ 50 ±0.5  
Angle ±0.3°

3RD. ANGEL'S

UNITS MM

DRAWN BY:	DATE	MAT'L	TITLE	JACK
Jack Lu	09/30/21		MODLE	PHONE JACK
CHECKED BY:	DATE	FINISH	SCALE	1 : 1
Jacky Chen	09/30/21		DWG NO.	PJ-2866D-3-S124
APPROVED BY:	DATE	SHEET NO.	PART NO.	PJ-2866D-3-S124
Tony Kao	09/30/21	1 of 1		

ITEM NO.	DESCRIPTION	DRAWN	DATE