

P.C.B LAYOUT

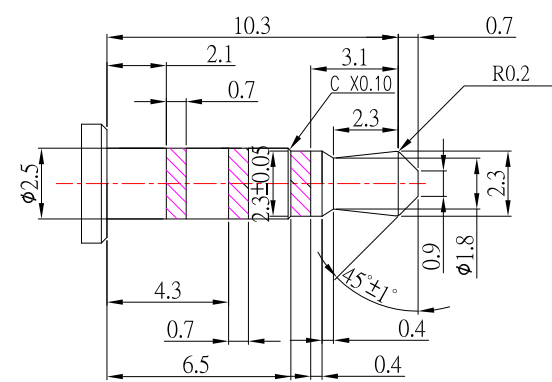

SPECIFICATION

- 1.Rating : DC 50V 0.3A
- 2.Contact resistance :  $\leq 30m\Omega$
- 3.Insulation resistance :  $\geq 100M\Omega$
- 4.Withstand voltage : 500VAC
- 5.Insertion and extraction force : 3-30N
- 6.life test : 5,000 cycles

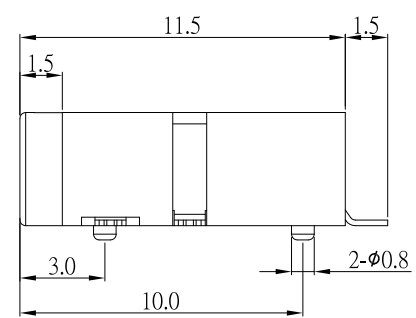
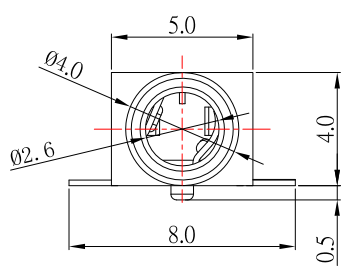
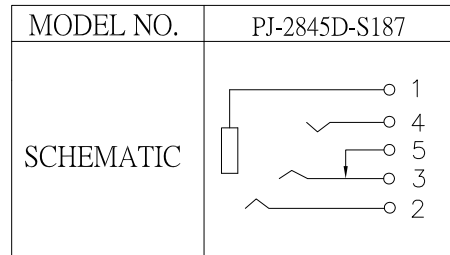

⑥	HOUSING	1	PA-9T (Black)	
⑤	TERMINAL #5	1	PHOSPHOR BRONZE	Ag-Plated
④	TERMINAL #4	1	PHOSPHOR BRONZE	Ag-Plated
③	TERMINAL #3	1	PHOSPHOR BRONZE	Ag-Plated
②	TERMINAL #2	1	PHOSPHOR BRONZE	Ag-Plated
①	TERMINAL #1	1	PHOSPHOR BRONZE	Ag-Plated
No.	PART NAME	QTY	MATERIAL (THICK, COLOR)	REMARK



TOLERANCE UNLESS OTHERWISE STATED:

Up to 5	$\pm 0.2$
Above 5 ~ 15	$\pm 0.3$
Above 15 ~ 30	$\pm 0.4$
Above 30 ~ 50	$\pm 0.5$
Angle	$\pm 0.3^\circ$

3RD. ANGEL'S

DRAWN BY:	DATE	MAT'L	TITLE	JACK
Jack Lu	11/04/15			
CHECKED BY:	DATE	FINISH	MODLE	PHONE JACK
Jacky Chen	11/04/15			
APPROVED BY:	DATE	SCALE	DWG NO.	PJ-2845D-S187
Tony Kao	11/04/15	1 : 1		
		SHEET NO.	PART NO.	PJ-2845D-S187
		1 of 1		
			SIZE	A4
			VER	R2

ITEM NO.	DESCRIPTION	DRAWN	DATE
2	新增SPEC	Jack	110415
1	更新料號	Jack	041814