

Ø2.5 MATE PLUG

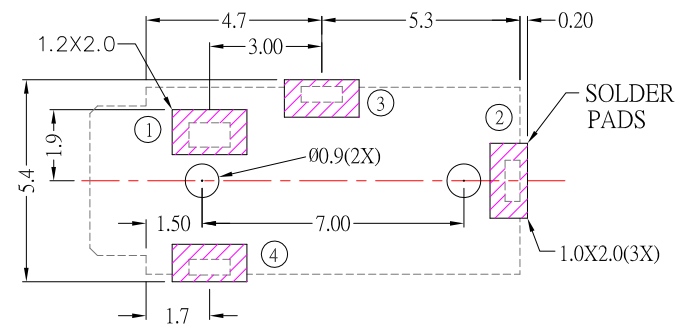

RECOMMENDED SOLDER PAD LAYOUT

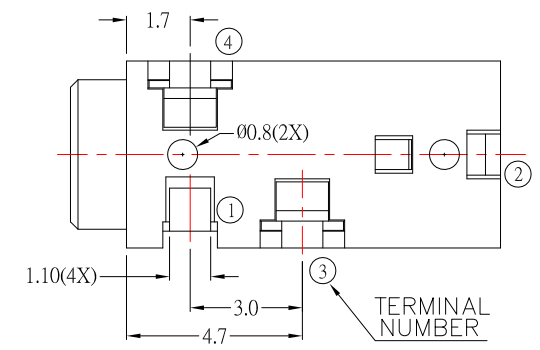

MODEL NO.	PJ-2784D	PJ-2783D
SCHEMATIC		

SPECIFICATION

1. Rating : DC 12V 1.0A
2. Contact resistance : $\leq 50m\Omega$
3. Insulation resistance : $\geq 100M\Omega$
4. Withstand voltage : 500VAC
5. Insertion and extraction force : 3-30N
6. life test : 5,000 cycles

*MATERIAL

- TERMINAL 1 :PHOSPHOR BRONZE
- TERMINAL 2 :PHOSPHOR BRONZE
- TERMINAL 3 :PHOSPHOR BRONZE
- TERMINAL 4 :PHOSPHOR BRONZE
- HOUSING :PA6T



TOLERANCE UNLESS OTHERWISE STATED :
 Up to 5 ±0.2
 Above 5 ~ 15 ±0.3
 Above 15 ~ 30 ±0.4
 Above 30 ~ 50 ±0.5
 Angle ±0.3°

3RD. ANGEL'S

UNITS MM

DRAWN BY:	DATE	MAT'L	TITLE	JACK
Jack Lu	11/04/15		MODLE	PHONE JACK
CHECKED BY:	DATE	SCALE	DWG NO.	PJ-278xD
Jacky Chen	11/04/15	5 : 1	PART NO.	PJ-278xD
APPROVED BY:	DATE	SHEET NO.	1 of 1	
Tony Kao	11/04/15			

ITEM NO.	DESCRIPTION	DRAWN	DATE
1	新增SPEC	Jack	110415