

P.C.B LAYOUT
TOP VIEW

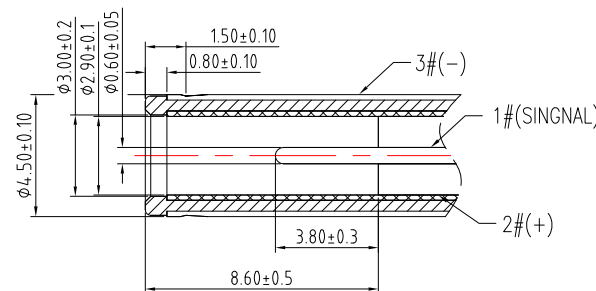
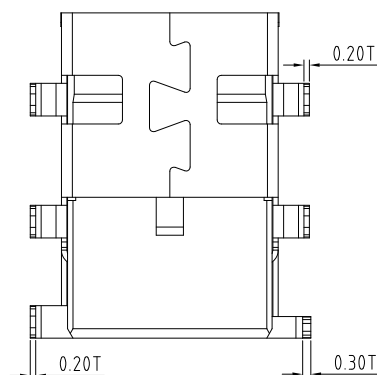

MATING PLUG

MODEL NO.	DC-S456H-0.6-HF
SCHEMATIC	\checkmark — \circ 2#(+)
	$>$ — \circ 1#(SIGNAL)
	\wedge — \circ 3#(-)

SPECIFICATION

1. Rating : DC 20V, 8.0A ;
2. Contact resistance : $\leq 30m\Omega$;
3. Insulation resistance : $\geq 100M\Omega$;
4. Withstand voltage : 500VAC ;
5. Insertion and extraction force : 6-30N;
6. Life test : 5,000 cycles °

4	SHELL	1	BRASS	Ni-Plating
3	SPRING	1	PHOSPHOR BRONZE	Au/Sn-Plated over Ni
2	CENTER PIN	1	PHOSPHOR BRONZE	Au/Sn-Plated over Ni
1	HOUSING	1	PA9T (BLACK)	
NO.	DESCRIPTION	QTY	MATERIAL	PLATING

東莞市高迪電子有限公司
DONG GUAN GAO DI ELECTRONICS CO., LTD

TOLERANCE UNLESS OTHERWISE STATED:
 Up to 5 ±0.2
 Above 5 ~ 15 ±0.3
 Above 15 ~ 30 ±0.4
 Above 30 ~ 50 ±0.5
 Angle ±0.3°

3RD. ANGEL'S

UNITS MM

DRAWN BY:	DATE	MAT'L	TITLE	JACK
Jack Lu	09/26/22			
CHECKED BY:	DATE	FINISH	MODLE	DC JACK
Jacky Chen	09/26/22			
APPROVED BY:	DATE	SCALE	DWG NO.	DC-S456H-0.6-HF-S214
Tony Kao	09/26/22	1 : 1		
		SHEET NO.	PART NO.	DC-S456H-0.6-HF-S214
		1 of 1		
				SIZE A4
				VER R

ITEM NO.	DESCRIPTION	DRAWN	DATE