

SECTION A-A

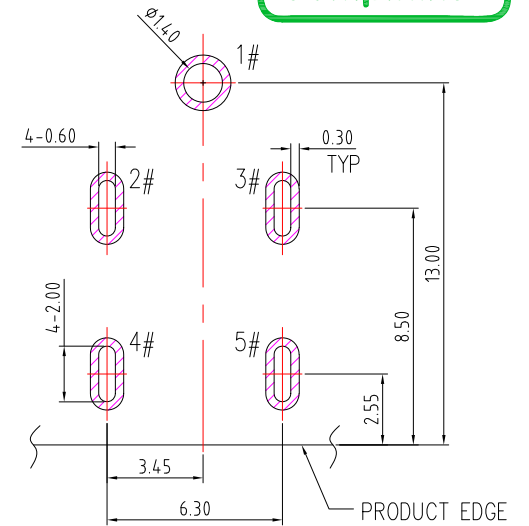

PCB LAYOUT
TOP VIEW

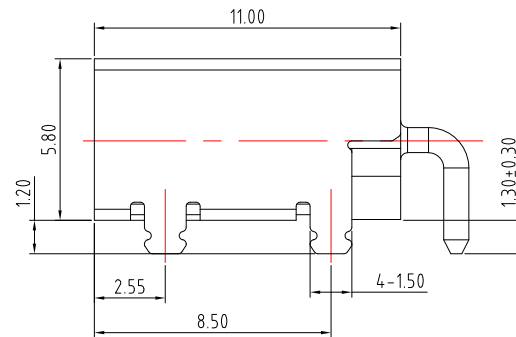
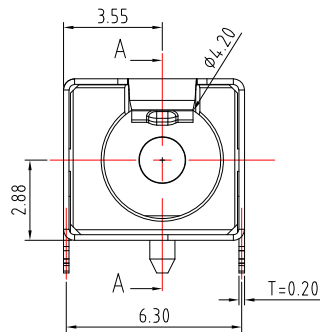
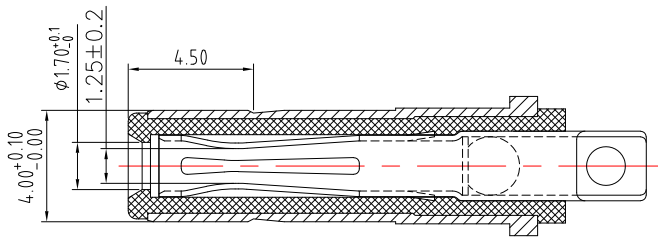

MATING PLUG

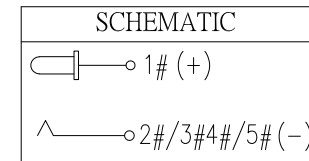
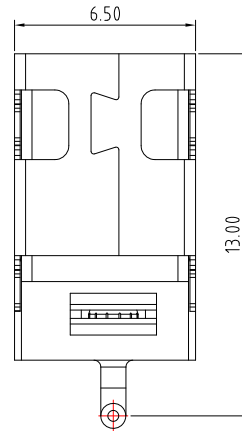

SPECIFICATION

1. Rating : DC 20V, 5.0A
2. Contact resistance : $\leq 30m\Omega$
3. Insulation resistance : $\geq 100M\Omega$
4. Withstand voltage : 500VAC
5. Insertion and extraction force : 5-30N
6. life test : 5,000 cycles

NO.	DESCRIPTION	MATERIAL	REMARKS	QTY
C	CENTER PIN	H59	GOLD Plated over Ni	1
B	SHELL	PHOSPHOR BRONZE	Ni Plated	1
A	HOUSING	PA10T	BLACK	1



TOLERANCE UNLESS OTHERWISE STATED :

Up to 5	±0.2
Above 5 ~ 15	±0.3
Above 15 ~ 30	±0.4
Above 30 ~ 50	±0.5
Angle	±0.3°

3RD. ANGEL'S UNITS MM

DRAWN BY:	DATE	MAT'L	TITLE	JACK
Jack Lu	08/20/24			
CHECKED BY:	DATE	FINISH	MODLE	DC JACK
Jacky Chen	08/20/24			
APPROVED BY:	DATE	SCALE	DWG NO.	DC-D3027EH-1.65-S457
Tony Kao	08/20/24	1 : 1		
SHEET NO.	1 of 1	PART NO.	DC-D3027EH-1.65-S457	
				SIZE A4
				VER R2

ITEM NO.	DESCRIPTION	DRAWN	DATE
2	更新life test	Jack	082024
1	更新尺寸	Jack	080124