

P.C.B LAYOUT
TOP VIEW

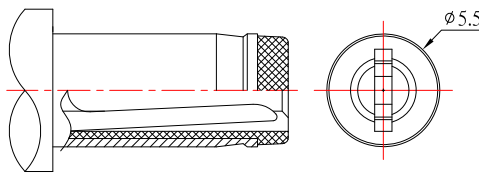
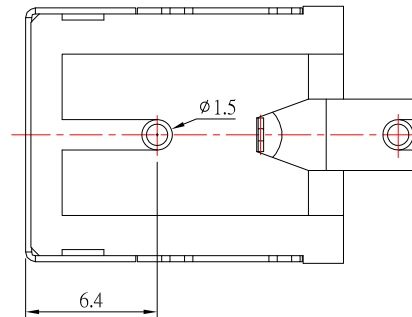
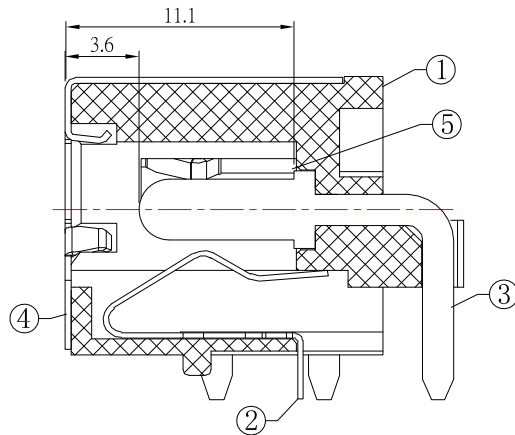

RECOMMENDED PLUG

Model NO.	DC-079HS-2.0	DC-079HS-2.5
PIN(X)	Ø2.0	Ø2.5

MODEL NO.	DC-079HS-x
SCHEMATIC	

SPECIFICATION

- 1.Rating : DC 54V, 5.0A
- 2.Contact resistance : ≤ 30mΩ
- 3.Insulation resistance : ≥ 100MΩ
- 4.Withstand voltage : 500VAC
- 5.Insertion and extraction force : 5-30N
- 6.life test : 5,000 cycles

NO.	DESCRIPTION	QTY	MATERIAL	PLATING
5	SPRING PIECE	1	SUS	Sn-Plating
4	COAT	1	SPCC	Ni-Plating
3	PIN	1	BRASS	Ni-Plating
2	SPRING PIECE	1	PHOSPHOR BRONZE	Sn-Plating
1	HOUSING	1	PA9T	

ITEM NO.	DESCRIPTION	DRAWN	DATE
2	更新Rating	Jack	082721
1	更新圖面	Jack	083120

東莞市高迪電子有限公司
DONG GUAN GAO DI ELECTRONICS CO., LTD

TOLERANCE UNLESS OTHERWISE STATED :
 Up to 5 ±0.2
 Above 5 ~ 15 ±0.3
 Above 15 ~ 30 ±0.4
 Above 30 ~ 50 ±0.5
 Angle ±0.3

3RD. ANGEL'S

UNITS MM

DRAWN BY:	DATE	MAT'L	TITLE	JACK
Jack Lu	08/27/21		MODLE	DC JACK
CHECKED BY:	DATE	FINISH	SCALE	1 : 1
Jacky Chen	08/27/21		DWG NO.	DC-079HS-x-S124
APPROVED BY:	DATE	SHEET NO.	PART NO.	DC-079HS-x-S124
Tony Kao	08/27/21	1 of 1		