

P.C.B LAYOUT
TOP VIEW

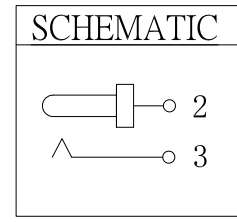

- SPECIFICATION**
- 1.Rating : DC 30V, 1.0A ;
 - 2.Contact resistance : $\leq 30m\Omega$;
 - 3.Insulation resistance : $\geq 100M\Omega$;
 - 4.Withstand voltage : 500VAC ;
 - 5.Insertion and extraction force : 2-20N;
 - 6.life test : 5,000 cycles °

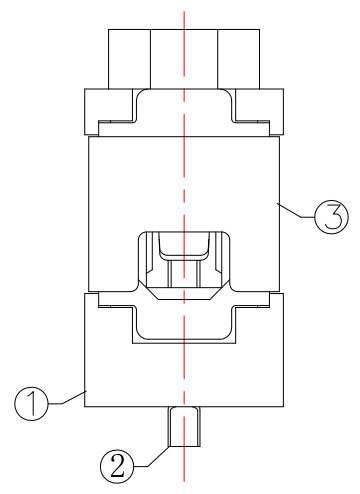
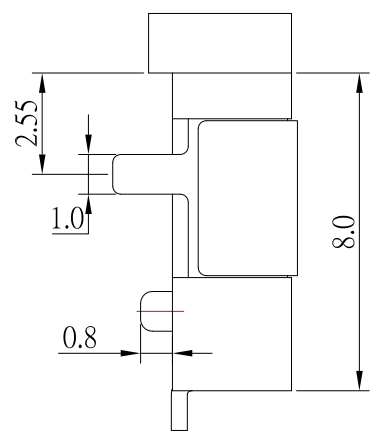
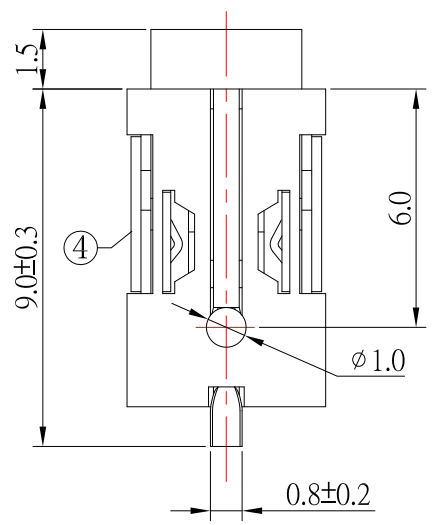
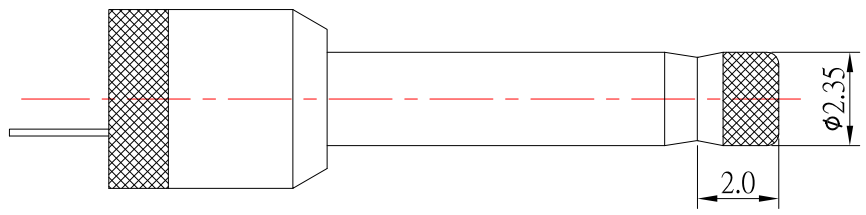

RECOMMENDED PLUG

NO.	DESCRIPTION	QTY	MATERIAL	PLATING
4	SPRING	1	PHOSPHOR BRONZE	Ag-Plating
3	SPRING	1	PHOSPHOR BRONZE	Ag-Plating
2	PIN	1	BRASS	Ag-Plating
1	HOUSING	1	PA9T	

東莞市高迪電子有限公司
DONG GUAN GAO DI ELECTRONICS CO., LTD

TOLERANCE UNLESS OTHERWISE STATED:
Up to 5 ±0.2
Above 5 ~ 15 ±0.3
Above 15 ~ 30 ±0.4
Above 30 ~ 50 ±0.5
Angle ±0.3°

3RD. ANGEL'S

UNITS MM

DRAWN BY:	DATE	MAT'L	TITLE	JACK
Jack Lu	04/14/23			
CHECKED BY:	DATE	FINISH	MODLE	DC JACK
Jacky Chen	04/14/23			
APPROVED BY:	DATE	SCALE	DWG NO.	DC-064D-6-S124
Tony Kao	04/14/23	1 : 1		
		SHEET NO.	PART NO.	DC-064D-6-S124
		1 of 1		

ITEM NO.	DESCRIPTION	DRAWN	DATE
2	新增尺寸	Jack	041423
1	更新尺寸	Jack	070821