

REFERENCE DRAWING (PLUG)

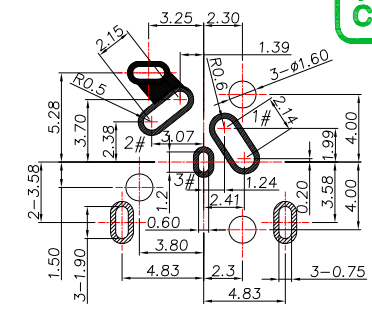

P.C.B LAYOUT
TOP VIEW

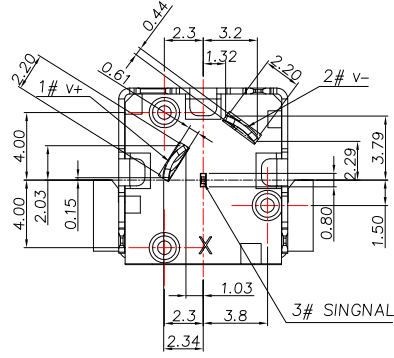
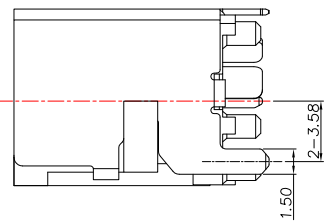
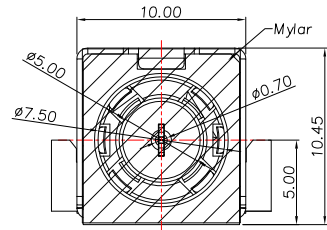

SCHEMATIC	
	2# V-
	1# V+
	3# SINGNAL

SPECIFICATION

- Rating : DC 30V, 5.0A
- Contact resistance : $\leq 30m\Omega$
- Insulation resistance : $\geq 100M\Omega$
- Withstand voltage : 150VAC
- Insertion and extraction force : 7-30N
- life test : 5,000 cycles

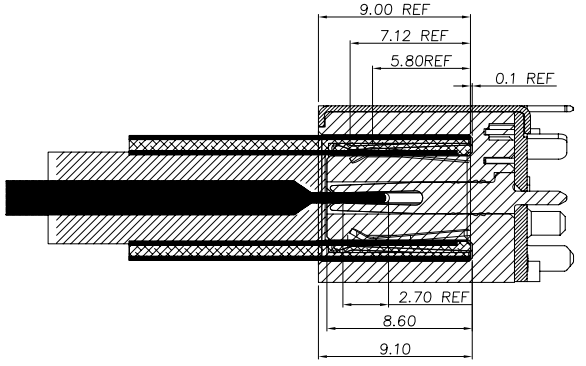

NO.	DESCRIPTION	QTY	MATERIAL	PLATING
⑥	MYLAR	1	PET	
⑤	HOUSING	1	PA10T	
④	SHELL	1	BRASS	Ni-Plating
③	CONTACT 3	1	PHOSPHOR BRONZE	Au+Ni-Plating
②	CONTACT 2	1	PHOSPHOR BRONZE	Au+Ni-Plating
①	CONTACT 1	1	PHOSPHOR BRONZE	Au+Ni-Plating



TOLERANCE UNLESS OTHERWISE STATED :
 Up to 5 ±0.2
 Above 5 ~ 15 ±0.3
 Above 15 ~ 30 ±0.4
 Above 30 ~ 50 ±0.5
 Angle ±0.3

3RD. ANGEL'S

UNITS MM

DRAWN BY:	DATE	MAT'L	TITLE	JACK
Jack Lu	10/31/19		MODLE	DC JACK
CHECKED BY:	DATE	SCALE	DWG NO.	DC-D3021VH-0.6-S214
Jacky Chen	10/31/19	1 : 1	PART NO.	DC-D3021VH-0.6-S214
APPROVED BY:	DATE	SHEET NO.	SIZE	A4
Tony Kao	10/31/19	1 of 1	VER	R

ITEM NO.	DESCRIPTION	DRAWN	DATE