

P.C.B LAYOUT
TOP VIEW

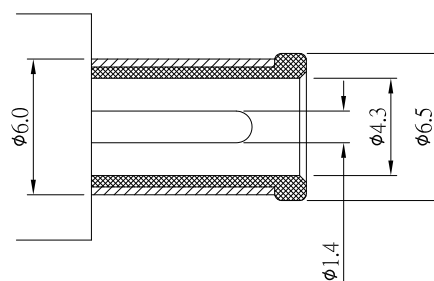
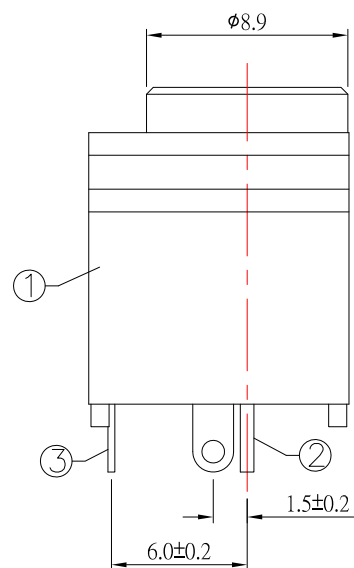

DC MATE PLUG

MODEL NO.	DC-D037-1.4
SCHEMATIC	

SPECIFICATION

- 1.Rating : DC 30V, 2.0A ;
- 2.Contact resistance : $\leq 30m\Omega$;
- 3.Insulation resistance : $\geq 100M\Omega$;
- 4.Withstand voltage : 500VAC ;
- 5.Insertion and extraction force : 3-20N;
- 6.life test : 5,000 cycles °

④	CONTACT FOOT	1	BRASS	Ag-Plating
③	SPRING	1	PHOSPHOR BRONZE	Ag-Plating
②	CURVE PIECE	1	PHOSPHOR BRONZE	Ag-Plating
①	HOUSING	1	PA9T	
NO.	DESCRIPTION	QTY	MATERIAL	PLATING

東莞市高迪電子有限公司
DONG GUAN GAO DI ELECTRONICS CO., LTD

TOLERANCE UNLESS OTHERWISE STATED :
 Up to 5 ±0.2
 Above 5 ~ 15 ±0.3
 Above 15 ~ 30 ±0.4
 Above 30 ~ 50 ±0.5
 Angle ±0.3

3RD. ANGEL'S UNITS MM

DRAWN BY:	DATE	MAT'L	TITLE	JACK
Jack Lu	01/22/18			
CHECKED BY:	DATE	FINISH	MODLE	DC JACK
Jacky Chen	01/22/18			
APPROVED BY:	DATE	SCALE	DWG NO.	DC-D037-1.4-S124
Tony Kao	01/22/18	1 : 1		
		SHEET NO.	PART NO.	DC-D037-1.4-S124
		1 of 1		
				SIZE A4
				VER R1

1	更新PCB LAYOUT	Jack	012218
ITEM NO.	DESCRIPTION	DRAWN	DATE