

P. C. B LAYOUT

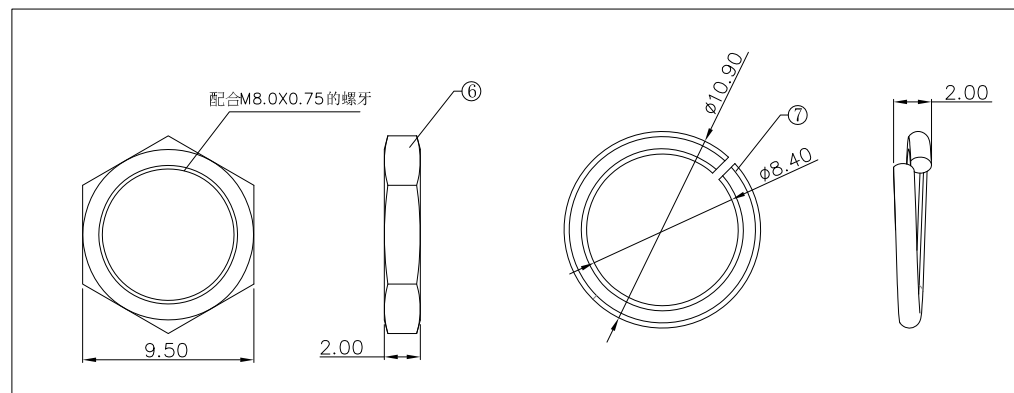
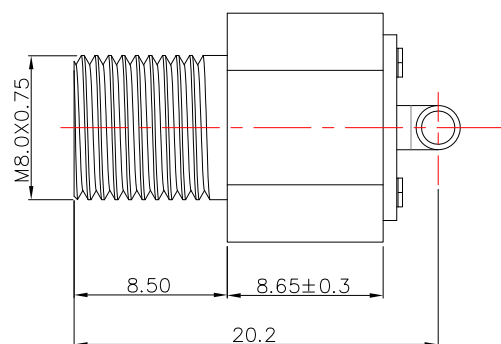

MODEL NO.	DC-D20105HM
SCHEMATIC	1 (+) 2 (-)

SPECIFICATION

1. Rating : DC 20V, 10.0A
2. Contact resistance : $\leq 30m\Omega$
3. Insulation resistance : $\geq 1500M\Omega$
4. Withstand voltage : 500VAC
5. Insertion and extraction force : 4 - 40N
6. life test : 5,000 cycles

NO.	DESCRIPTION	QTY	MATERIAL	REMARK
⑦	HARDWARE CIRCLE	1	SUS	
⑥	NUT	1	BRASS	Ni-Plating
⑤	HOUSING	1	PA9T	
④	PEG	1	BRASS	
③	CONTACT FOOT	1	ZINC ALLOY	Ni-Plating
②	CONTACT FOOT	1	PHOSPHOR BRONZE	Sn-Plating
①	PIN	1	ZINC ALLOY	Ni-Plating

東莞市高迪電子有限公司
DONG GUAN GAO DI ELECTRONICS CO., LTD

TOLERANCE UNLESS OTHERWISE STATED:
 Up to 5 ±0.2
 Above 5 ~ 15 ±0.3
 Above 15 ~ 30 ±0.4
 Above 30 ~ 50 ±0.5
 Angle ±0.3°

3RD. ANGEL'S UNITS MM

DRAWN BY:	DATE	MAT'L	TITLE	JACK
Jack Lu	02/21/24		MODLE	DC JCAK
CHECKED BY:	DATE	FINISH	SCALE	1 : 1
Jacky Chen	02/21/24		DWG NO.	DC-D20105HM-2.5-S457
APPROVED BY:	DATE	SHEET NO.	PART NO.	DC-D20105HM-2.5-S457
Tony Kao	02/21/24	1 of 1		

ITEM NO.	DESCRIPTION	DRAWN	DATE