

P. C. B LAYOUT
TOP VIEW

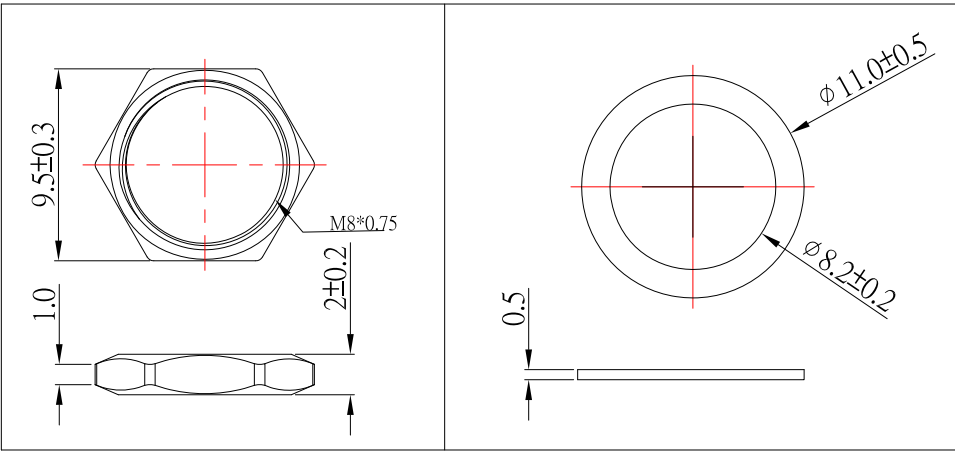

MODEL NO.	DC-D125M-x
SCHEMATIC	
CENTER PIN	φ2.0mm
	φ2.5mm

SPECIFICATION

- Rating : DC 30V, 5.0A
- Contact resistance : ≤ 30mΩ
- Insulation resistance : ≥ 100MΩ
- Withstand voltage : 500VAC
- Insertion and extraction force : 3-20N
- life test : 5,000 cycles

NO.	DESCRIPTION	QTY	MATERIAL	PLATING
10	SPLIT WASHER	1	IRON	Ni-Plating
9	NUT	1	H59	Ni-Plating
8	INSULATOR A	1	PF	
7	INSULATOR A	1	PF	
6	HOUSING	1	PBT	
5	AXIS SUPPORT	1	H59	Ni-Plating
4	PIN	1	H59	Ni-Plating
3	FLAT PIECE	1	BRASS	Sn-Plating
2	CURVE PIECE	1	BRASS	Sn-Plating
1	SPRING	1	PHOSPHOR BRONZE	Sn-Plating

ITEM NO.	DESCRIPTION	DRAWN	DATE
6	更新材質	Jack	110422
5	更新華司尺寸及PCB LAYOUT樣式	Jack	021722
4	更新華司樣式	Jack	102821
3	新增尺寸及更新尺寸	Jack	102021
2	更新圖面	Jack	080320
1	更新PCB LAYOUT尺寸	Jack	122719

東莞市高迪電子有限公司
DONG GUAN GAO DI ELECTRONICS CO., LTD

TOLERANCE UNLESS OTHERWISE STATED:
 Up to 5 ±0.2
 Above 5 ~ 15 ±0.3
 Above 15 ~ 30 ±0.4
 Above 30 ~ 50 ±0.5
 Angle ±0.3°

3RD. ANGEL'S

UNITS MM

DRAWN BY:	DATE	MAT'L	TITLE	JACK
Jack Lu	11/04/22			
CHECKED BY:	DATE	FINISH	MODLE	DC JACK
Jacky Chen	11/04/22			
APPROVED BY:	DATE	SCALE	DWG NO.	DC-D125M-x-S124
Tony Kao	11/04/22	1 : 1		
		SHEET NO.	PART NO.	DC-D125M-x-S124
		1 of 1		
				SIZE A4
				VER R6