

P.C.B LAYOUT MOUNTING PATTERN
(TOP VIEW)

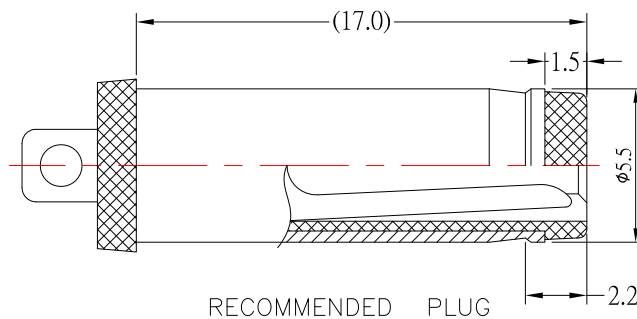
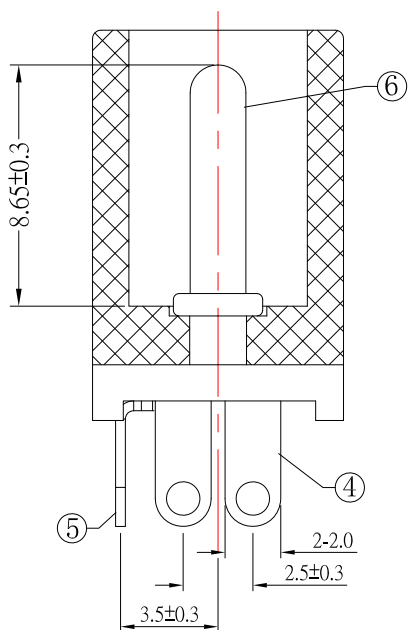

MODEL NO.	DC-D012D-x-S124
SCHMATIC	
CENTER PIN	$\phi 2.0\text{mm}$ $\phi 2.5\text{mm}$

SPECIFICATION

- Rating : DC 30V, 1.0A / 16V 3.0A ;
- Contact resistance : $\leq 30\text{m}\Omega$;
- Insulation resistance : $\geq 100\text{M}\Omega$;
- Withstand voltage : 500VAC ;
- Insertion and extraction force : 3-30N;
- life test : 5,000 cycles °

NO.	DESCRIPTION	QTY	MATERIAL	REMARK
⑥	PIN	1	BRASS	Ni-Plated
⑤	CURVE PIECE	1	BRASS	Sn-Plated
④	FLAT PIECE	1	BRASS	Sn-Plated
③	SPRING	1	PHOSPHOR BRONZE	Sn-Plated
②	COVER	1	PBT	
①	HOUSING	1	PBT	

ITEM NO.	DESCRIPTION	DRAWN	DATE
4	更新圖面	Jack	113022
3	更新材質	Jack	081017
2	更新Rating	Jack	061217
1	更新材質	Jack	032917

東莞市高迪電子有限公司
DONG GUAN GAO DI ELECTRONICS CO., LTD

TOLERANCE UNLESS OTHERWISE STATED:
 Up to 5 ±0.2
 Above 5 ~ 15 ±0.3
 Above 15 ~ 30 ±0.4
 Above 30 ~ 50 ±0.5
 Angle ±0.3°

3RD. ANGEL'S

UNITS MM

DRAWN BY:	DATE	MAT'L	TITLE	JACK
Jack Lu	11/30/22		MODLE	DC JACK
CHECKED BY:	DATE	FINISH	SCALE	1 : 1
Jacky Chen	11/30/22		DWG NO.	DC-D012D-x-S124
APPROVED BY:	DATE	SHEET NO.	PART NO.	DC-D012D-x-S124
Tony Kao	11/30/22	1 of 1		

SIZE
A4
VER
R4