

P.C.B LAYOUT
TOP VIEW

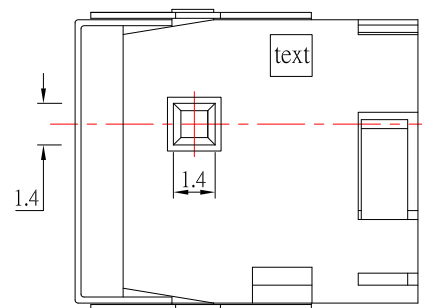
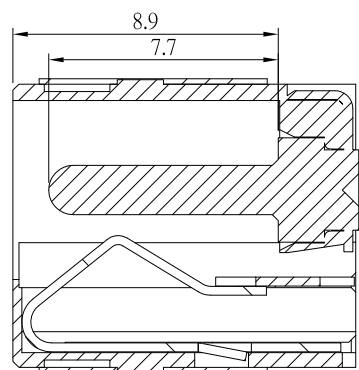

SPECIFICATION

- 1.Rating : DC 20V 5.0A
- 2.Contact resistance : $\leq 30m\Omega$
- 3.Insulation resistance : $\geq 100M\Omega$
- 4.Withstand voltage : 500VAC
- 5.Insertion and extraction force : 3-30N
- 6.life test : 5,000 cycles

MODEL NO.	DC-069HS-x
SCHEMATIC	
CENTER PIN(X)	$\phi 2.0$ mm $\phi 2.5$ mm

7	COVER	1	SUS	Ni-Plating
6	CONTACT FOOT	1	BRASS	Tin-Plating
5	PIN	1	BRASS	Ni-Plating
4	CONTACT FOOT	1	BRASS	Ag-Plating
3	CURVE PIECE	1	BRASS	Ag-Plating
2	SPRING PIECE	1	PHOSPHOR BRONZE	Ag-Plating
1	HOUSING	1	PA9T	Black
NO.	DESCRIPTION	QTY	MATERIAL	PLATING

10	更新樣式	Ian	041719
9	新增尺寸	Jack	100418
8	更新料號	Jack	050318
7	更新材質及鍍層	Jack	080417
6	更新life test	Jack	072817
5	更新圖面樣式	Jack	051017
4	新增PLUG圖示	Jack	011017
3	更新腳位編號	Jack	010617
2	更新為A0版	Jack	060816
1	更新Rating	Jack	121515
ITEM NO.	DESCRIPTION	DRAWN	DATE

13	更新料號	Jack	061821
12	新增尺寸	Jack	103019
11	更新MODLE	Jack	073119

東莞市高迪電子有限公司
DONG GUAN GAO DI ELECTRONICS CO., LTD

TOLERANCE UNLESS OTHERWISE STATED :
 Up to 5 ±0.2
 Above 5 ~ 15 ±0.3
 Above 15 ~ 30 ±0.4
 Above 30 ~ 50 ±0.5
 Angle ±0.3

3RD. ANGEL'S

UNITS MM

DRAWN BY:	DATE	MAT'L	TITLE	JACK
Jack Lu	06/18/21			
CHECKED BY:	DATE	FINISH	MODLE	DC JACK 高電流 / 帶彈片帶外殼
Jacky Chen	06/18/21			
APPROVED BY:	DATE	SCALE	DWG NO.	DC-069HS-x-S214
Tony Kao	06/18/21	1 : 1		
		SHEET NO.	PART NO.	DC-069HS-x-S214
		1 of 1		
			SIZE	A4
			VER	R13