

P.C.B LAYOUT  
TOP VIEW

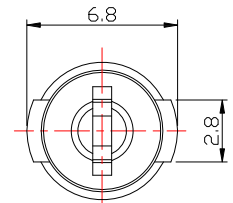

RECOMMENDED PLUG

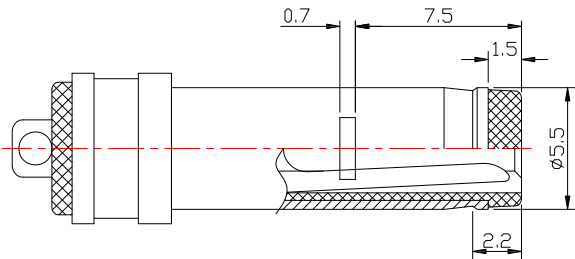
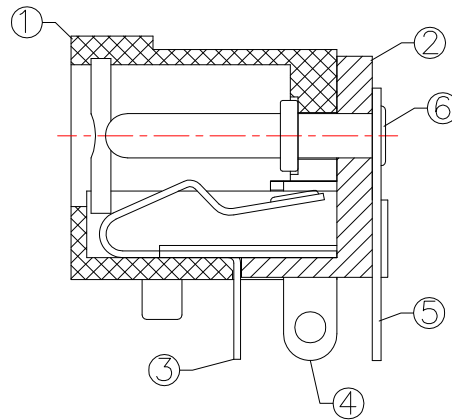

MODEL NO.	DC-062-4-x
SCHEMATIC	
CENTER PIN	φ2.0mm
	φ2.5mm

**SPECIFICATION**

1. Rating : DC 30V , 3.0A
2. Contact resistance : ≤30mΩ
3. Insulation resistance : ≥100MΩ
4. Withstand voltage : 500VAC
5. Insertion and extraction force : 3-30N
6. life test : 5,000 cycles

NO.	DESCRIPTION	QTY	MATERIAL	PLATING
⑥	PIN	1	BRASS	Ni-Plating
⑤	FLAT FOOT	1	BRASS	Sn-Plating
④	CURVE PIECE	1	BRASS	Sn-Plating
③	SPRING PIECE	1	PHOSPHOR BRONZE	Sn-Plating
②	COVER	1	PBT	
①	HOUSING	1	PBT	

東莞市高迪電子有限公司  
DONG GUAN GAO DI ELECTRONICS CO., LTD

TOLERANCE UNLESS OTHERWISE STATED :  
 Up to 5 ±0.2  
 Above 5 ~ 15 ±0.3  
 Above 15 ~ 30 ±0.4  
 Above 30 ~ 50 ±0.5  
 Angle ±0.3

3RD. ANGEL'S

UNITS MM

DRAWN BY:	DATE	MAT'L	TITLE	JACK
Jack Lu	06/01/21		MODLE	DC JACK 帶鎖
CHECKED BY:	DATE	FINISH	SCALE	1 : 1
Jacky Chen	06/01/21		DWG NO.	DC-062-4-x-S124
APPROVED BY:	DATE	SHEET NO.	PART NO.	DC-062-4-x-S124
Tony Kao	06/01/21	1 of 1		

ITEM NO.	DESCRIPTION	DRAWN	DATE