

P.C.B LAYOUT
TOP VIEW

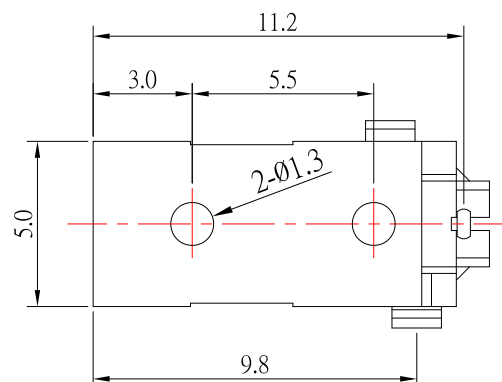

SCHEMATIC

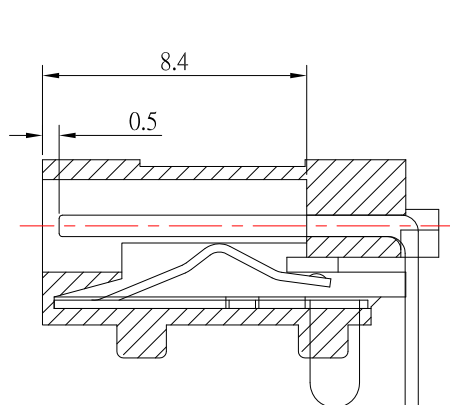
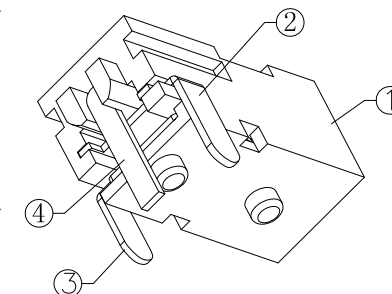
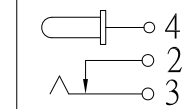

SPECIFICATION

1. Rating : DC 30V 1.0A ;
2. Contact resistance : $\leq 30m\Omega$;
3. Insulation resistance : $\geq 100M\Omega$;
4. Withstand voltage : 500VAC ;
5. Insertion and extraction force : 3-20N;
6. life test : 5,000 cycles °

NO.	DESCRIPTION	QTY	MATERIAL	PLATING
4	PIN	1	PHOSPHOR BRONZE	Ag-Plating
3	SPRING	1	SUS	Ag-Plating
2	FLAT PIECE	1	BRASS	Ag-Plating
1	HOUSING	1	PBT	



TOLERANCE UNLESS OTHERWISE STATED :
 Up to 5 ±0.2
 Above 5 ~ 15 ±0.3
 Above 15 ~ 30 ±0.4
 Above 30 ~ 50 ±0.5
 Angle ±0.3

3RD. ANGEL'S

UNITS MM

DRAWN BY:	DATE	MAT'L	TITLE	JACK
Jack Lu	03/13/17		MODLE	DC JACK
CHECKED BY:	DATE	FINISH	SCALE	1 : 1
Jacky Chen	03/13/17		DWG NO.	DC-027-0.65-S124
APPROVED BY:	DATE	SHEET NO.	PART NO.	DC-027-0.65-S124
Tony Kao	03/13/17	1 of 1		

ITEM NO.	DESCRIPTION	DRAWN	DATE
1	新增剖面圖	Jack	031317

SIZE A4
VER R1