

MODEL NO.	DC-021-1-x-S124
SCHEMATIC	
CENTER PIN	φ2.0 mm
	φ2.5 mm

### SPECIFICATION

1. Rating : DC 16V , 3.0A
2. Contact resistance : ≤ 30mΩ
3. Insulation resistance : ≥ 100MΩ
4. Withstand voltage : 500VAC
5. Insertion and extraction force : 3-20N
6. life test : 5,000 cycles

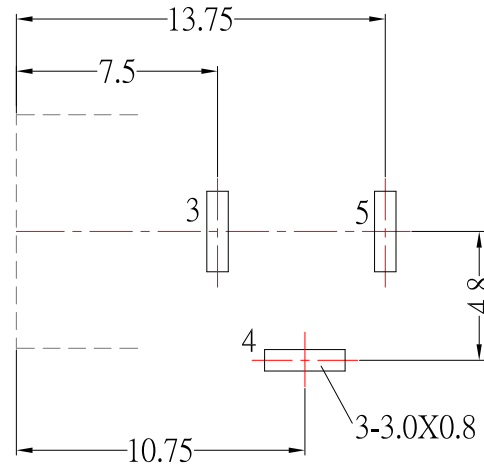
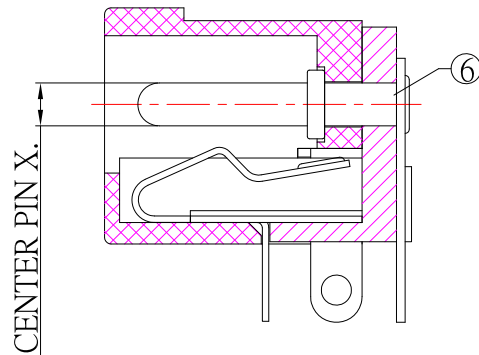

P.C.B LAYOUT MOUNTING PATTERN  
(TOP VIEW)

6	PIN	1	Brass	Ni-Plating
5	FLAT FOOT	1	Brass	Sn-Plating
4	CURVE PIECE	1	Brass	Sn-Plating
3	SPRING PIECE	1	Phosphor Bronze	Sn-Plating
2	COVER	1	PBT	
1	HOUSING	1	PBT	
NO.	DESCRIPTION	QTY	MATERIAL	REMARK



TOLERANCE UNLESS OTHERWISE STATED:  
 Up to 5 ±0.2  
 Above 5 ~ 15 ±0.3  
 Above 15 ~ 30 ±0.4  
 Above 30 ~ 50 ±0.5  
 Angle ±0.3

3RD. ANGEL'S

UNITS MM

DRAWN BY:	DATE	MAT'L	TITLE	JACK
Jack Lu	04/23/19		MODLE	DC JACK
CHECKED BY:	DATE	FINISH	SCALE	1 : 1
Jacky Chen	04/23/19		DWG NO.	DC-021-1-x-S124
APPROVED BY:	DATE	SHEET NO.	PART NO.	DC-021-1-x-S124
Tony Kao	04/23/19	1 of 1		
			SIZE	A4
			VER	R2

2	更新樣式	Lan	042319
1	更新Rating	Jack	011817
ITEM NO.	DESCRIPTION	DRAWN	DATE