

P.C.B LAYOUT
TOP VIEW

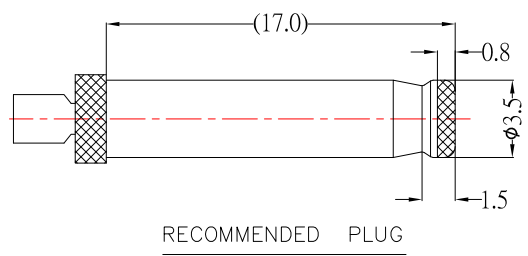
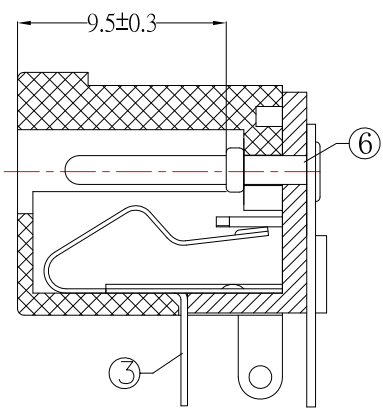

SPECIFICATION

1. Rating : DC 16V , 3.0A ;
2. Contact resistance : $\leq 30m\Omega$;
3. Insulation resistance : $\geq 100M\Omega$;
4. Withstand voltage : 500VAC ;
5. Insertion and extraction force : 3-30N;
6. life test : 5,000 cycles .

MODEL NO.	DC-014-1-x-S124
SCHEMATIC	
CENTER PIN	$\phi 1.0mm$
	$\phi 1.3mm$

NO.	DESCRIPTION	QTY	MATERIAL	PLATING
6	PIN	1	BRASS	Ni-Plating
5	FLAT FOOT	1	BRASS	Ag-Plating
4	CURVE PIECE	1	BRASS	Ag-Plating
3	SPRING PIECE	1	PHOSPHOR BRONZE	Ag-Plating
2	COVER	1	PBT	
1	HOUSING	1	PBT	

ITEM NO.	DESCRIPTION	DRAWN	DATE
6	更新SPEC和材質鍍層	Jack	050423
5	更新圖面尺寸	Jack	042222
4	更新Rating和PCB LAYOUT孔位樣式	Jack	111621
3	更新圖面	Jack	110320
2	更新PCB LAYOUT尺寸及新增PLUG圖	Jack	020618
1	更新為A0版	Jack	051717



TOLERANCE UNLESS OTHERWISE STATED :	Up to 5 ±0.2	3RD. ANGEL'S	UNITS	MM
	Above 5 ~ 15 ±0.3			
	Above 15 ~ 30 ±0.4			
	Above 30 ~ 50 ±0.5			
	Angle ±0.3°			

DRAWN BY:	DATE	MAT'L	TITLE	JACK
Jack Lu	05/04/23			
CHECKED BY:	DATE	FINISH	MODLE	DC JACK DIP TYPE
Jacky Chen	05/04/23			
APPROVED BY:	DATE	SCALE	DWG NO.	DC-014-1-x-S124
Tony Kao	05/04/23	1 : 1		
		SHEET NO.	PART NO.	DC-014-1-x-S124
		1 of 1		
			SIZE	A4
			VER	R6