

- 1、All dimensions in mm
- 2、Electrical rating : 3A 250VAC & 3A 125VAC
- 3、Contact resistance : 20mΩ (initial)
- 4、Insulation resistance : 1,000MΩ (500V DC between open contacts)
- 5、Dielectric strength : >1,500V AC 1 minute
- 6、Mechanical life : >30,000 cycles
- 7、Electrical life : >10,000 cycles
- 8、Temperature rise at the terminal : Max.30°C
- 9、Solder ability of terminal : Max350°C, 3S
(no pressure may be placed in the terminals when soldering by hand)
- 10、Any Cd Pb Hg etc and it's compounds is not include in this product

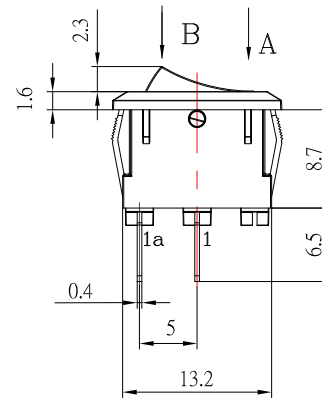

Color	Housing	Actuare
K(Black)	✓	✓
W(White)		
R(Red)		
G(Gray)		
O(Orange)		
B(Blue)		
Y(III. Yellow)		
M(III. Green)		
F(III. Blue)		
T(III. White)		

POLE FUNCTION	OPTIONS OF FUNCTION		
	A	—	B
SPST	1-1a	—	OFF

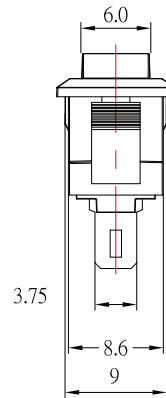
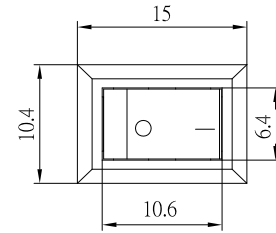
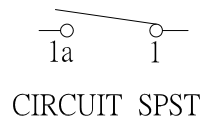
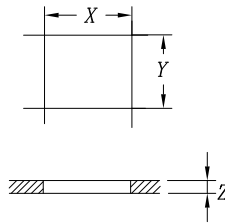

PANEL OUT-CUT		
Z	Y	X
0.7~1.25	9.1~9.2	13.6~13.8
1.25~2.0	9.1~9.2	13.8~14.0
2.0~3.0	9.1~9.2	14.0~14.1

A	B	C	D	E	F	G	H	I
					✓			



TOLERANCE UNLESS OTHERWISE STATED :
 Up to 5 ±0.2
 Above 5 ~ 15 ±0.3
 Above 15 ~ 30 ±0.4
 Above 30 ~ 50 ±0.5
 Angle ±0.3°

3RD. ANGEL'S

UNITS MM

DRAWN BY:	DATE	MAT'L	TITLE	SWITCH
Jack Lu	07/10/13			
CHECKED BY:	DATE	FINISH	MODLE	ROCKER SWITCH
Jacky Chen	07/10/13			
APPROVED BY:	DATE	SCALE	DWG NO.	MRA12KKFT0F
Tony Kao	07/10/13	2 : 1		
		SHEET NO.	PART NO.	MRA12KKFT0F
		1 of 1		
				SIZE A4
				VER R1

ITEM NO.	DESCRIPTION	DRAWN	DATE
1	更新開關位置	Jack	071013