

IP67

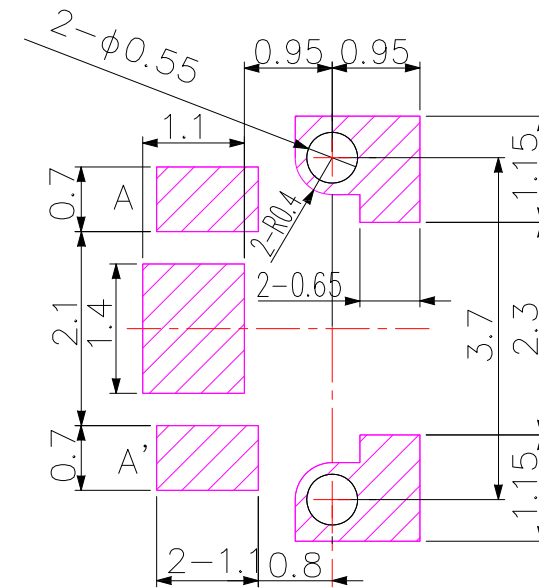

P.C.B LAND PATTERN & HOLE

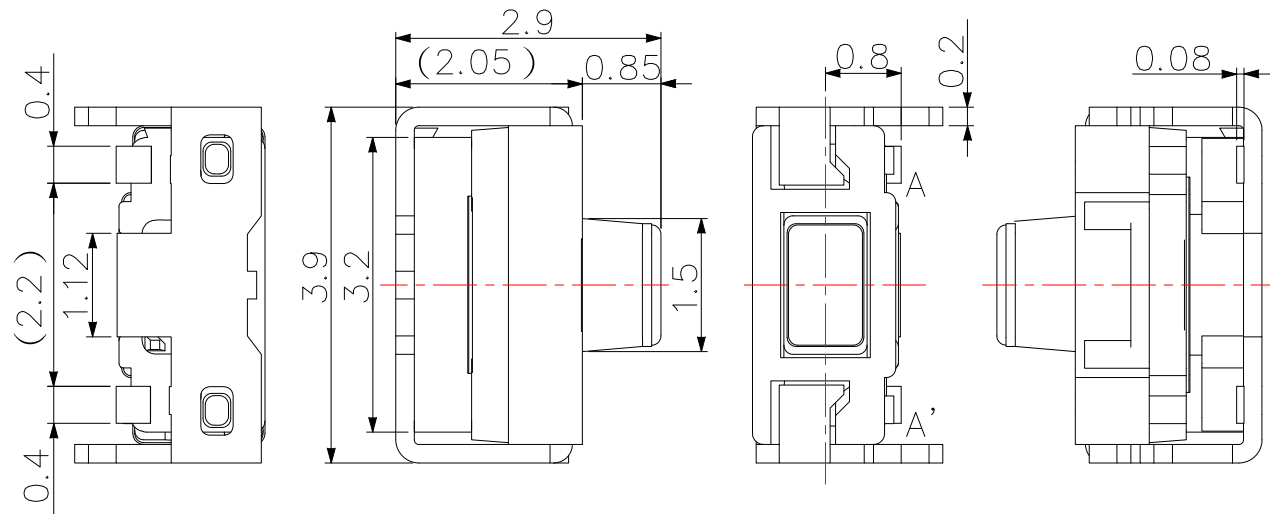
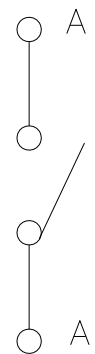
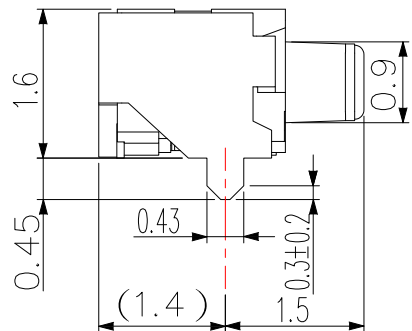

CIRCUIT DIAGRAM

SPECIFICATIONS

Rating	DC 15V 20mA
Contact Resistance	100mΩ Max.
Travel	0.12 mm
Operating Force	160 ± 50gf
Operating Life (cycles)	500,000

东莞市高迪电子有限公司
DONG GUAN GAO DI ELECTRONICS CO., LTD

TOLERANCE UNLESS OTHERWISE STATED:
 Up to 5 ±0.2
 Above 5 ~ 30 ±0.3
 Above 30 ~ 50 ±0.4
 Above 50 ±0.5
 Angle ±0.3°

3RD. ANGEL'S



UNITS MM

DRAWN BY:	DATE	MAT'L	TITLE	SWITCH
Jack Lu	06/07/21		MODLE	TACT SWITCH R/A WATERPROOF TYPE
CHECKED BY:	DATE	SCALE	DWG NO.	TS-309W-2-S182
Jacky Chen	06/07/21	1 : 1	PART NO.	TS-309W-2-S182
APPROVED BY:	DATE	SHEET NO.		
Tony Kao	06/07/21	1 of 1		

ITEM NO.	DESCRIPTION	DRAWN	DATE