

# TS-A09VS1x-3-S246

MODEL NO.	X(mm)
BLANK	3.8
A	4.3
B	4.8
C	5.0
E	7.0

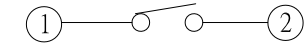

CIRCUIT DIAGRAM

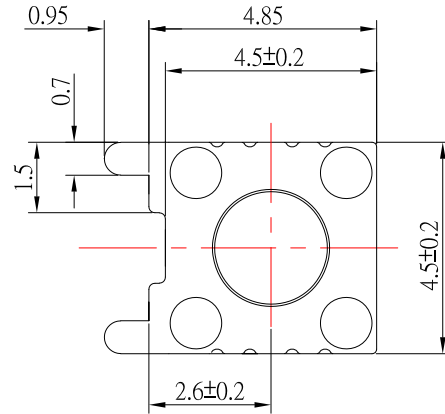
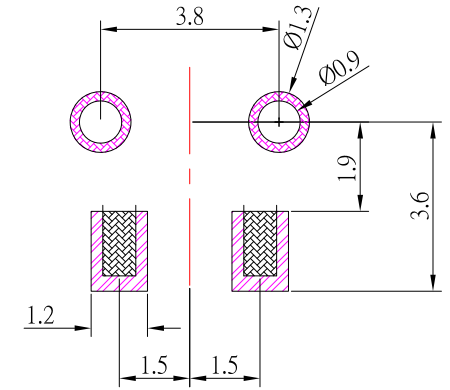

PCB LAYOUT

## SPECIFICATIONS

Rating	DC 12V 0.05A.
Insulation Resistance	100 MΩ Min.
Contact Resistance	100 mΩ Max.
Operating Force	260 ± 50gf
Operating Life (cycles)	100,000
Travel	0.20± 0.10mm

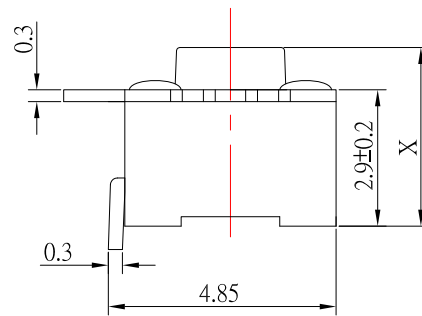
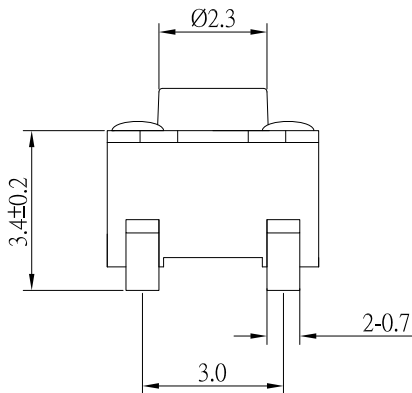

NO.	DESCRIPTION	QTY	MATERIAL	PLATING
E	COVER	1	BRASS	Ag plated
D	STEM	1	PPA	Black
C	CONTACT	1	SUS	Ag plated
B	TERMINAL	2	BRASS	Ag plated
A	BASE	1	PA6T	Black

**東莞市高迪電子有限公司**  
DONG GUAN GAO DI ELECTRONICS CO., LTD

TOLERANCE UNLESS OTHERWISE STATED :  
 Up to 5 ±0.2  
 Above 5 ~ 15 ±0.3  
 Above 15 ~ 30 ±0.4  
 Above 30 ~ 50 ±0.5  
 Angle ±0.3

3RD. ANGEL'S

UNITS MM

DRAWN BY:	DATE	MAT'L	TITLE	SWITCH
Jack Lu	07/16/24	FINISH	MODE	TACT SWITCH
CHECKED BY:	DATE	SCALE	DWG NO.	TS-A09VS1x-3-S246
Jacky Chen	07/16/24	1 : 1	PART NO.	TS-A09VS1x-3-S246
APPROVED BY:	DATE	SHEET NO.	1 of 1	
Tony Kao	07/16/24			