

PCB LAYOUT MOUNTING PATTERN

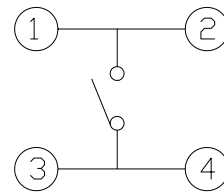
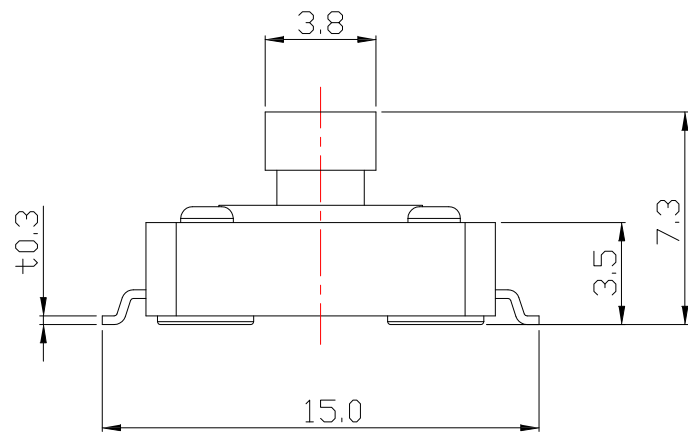

CIRCUIT DIAGRAM

SPECIFICATIONS

| | | | | |
|------------------------|-------------|----------|---|----------|
| Rating | DC 12V 50mA | | | |
| Contact Resistance | 100mΩ Max. | | | |
| Travel | 0.3 ± 0.1mm | | | |
| Operating Force | 2 | 160±50gf | 3 | 250±50gf |
| Operating Life(cycles) | 100,000 | | | |

東莞市高迪電子有限公司
DONG GUAN GAO DI ELECTRONICS CO., LTD

TOLERANCE UNLESS OTHERWISE STATED:
Up to 5 ±0.2
Above 5 ~ 15 ±0.3
Above 15 ~ 30 ±0.4
Above 30 ~ 50 ±0.5
Angle ±0.3°

3RD. ANGEL'S



UNITS

MM

DRAWN BY: Jack Lu
CHECKED BY: Jacky Chen
APPROVED BY: Tony Kao
DATE: 01/06/16

MAT'L
FINISH
SCALE: 1 : 1
SHEET NO.: 1 of 1

TITLE: SWITCH
MODLE: TACT SWITCH
DWG NO.: TS-A03ST-x-S126
PART NO.: TS-A03ST-x-S126

SIZE: A4
VER: R

| ITEM NO. | DESCRIPTION | DRAWN | DATE |
|----------|-------------|-------|------|
| | | | |
| | | | |
| | | | |