

DIMENSIONS

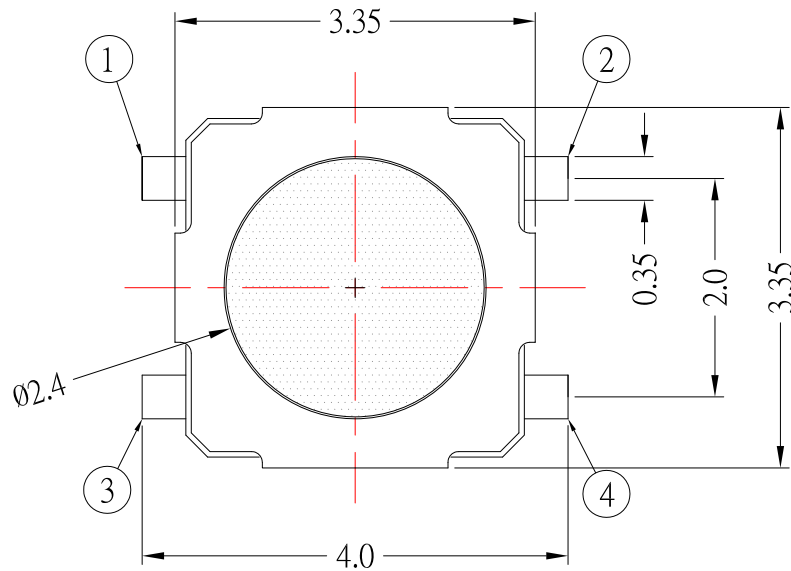

P.C.B LAYOUT MOUNTING PATTERN

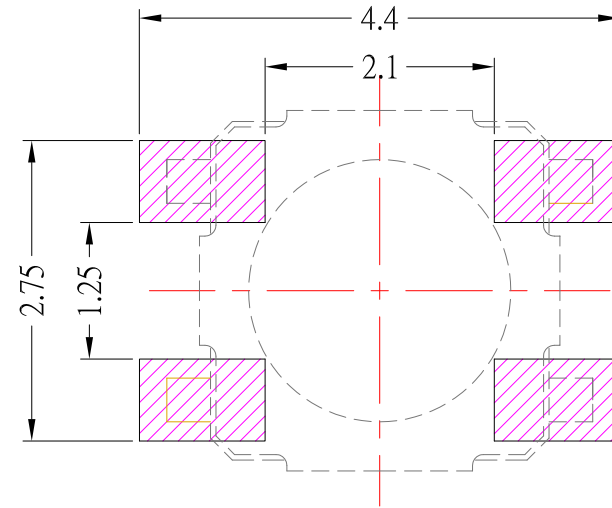

CIRCUIT DIAGRAM

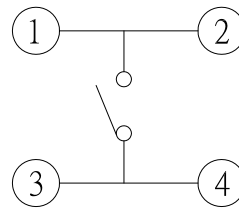

SPECIFICATIONS

Rating	DC 12V 50mA Max.	
Contact Resistance	100mΩ Max.	
Travel	0.15 ± 0.1mm	
Operating Force	2:160±50gf	3:260±50gf
Operating Life (cycles)	100,000	

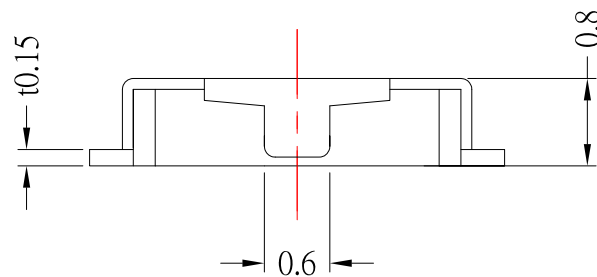

 **東莞市高迪電子有限公司**
DONG GUAN GAO DI ELECTRONICS CO., LTD

TOLERANCE UNLESS OTHERWISE STATED:
 Up to 5 ±0.2
 Above 5 ~ 15 ±0.3
 Above 15 ~ 30 ±0.4
 Above 30 ~ 50 ±0.5
 Angle ±0.3°

3RD. ANGEL'S



UNITS MM

DRAWN BY:	DATE	MAT'L	TITLE	SWITCH
Frank Wu	06/26/12		MODLE	TACT SWITCH
CHECKED BY:	DATE	FINISH	SCALE	1 : 1
Jacky Chen	06/26/12		DWG NO.	TS-307PF-x-S126
APPROVED BY:	DATE	SHEET NO.	PART NO.	TS-307PF-x-S126
Tony Kao	06/26/12	1 of 1		

ITEM NO.	DESCRIPTION	DRAWN	DATE