

SCHMATIC (NON-SHORTING)

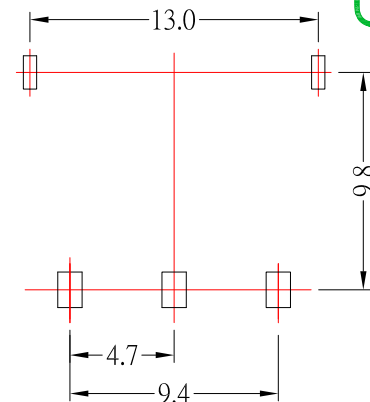

P.C.B LAYOUT
BOTTOM VIEW

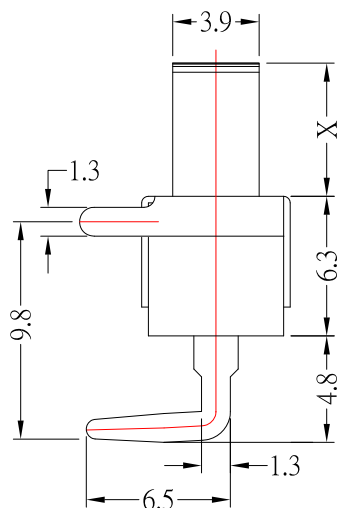
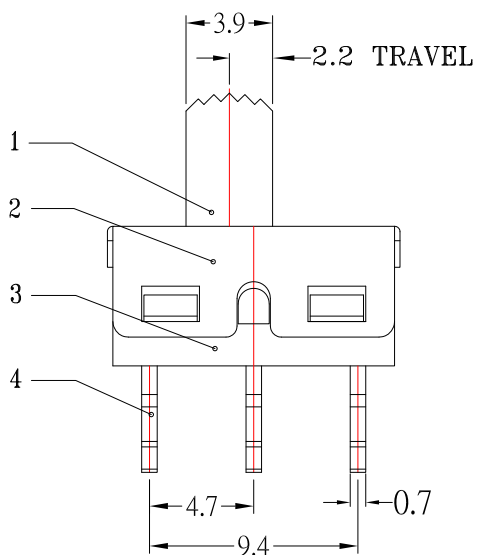

Model No.	X(mm)
SS-12D11-GA3	3mm
SS-12D11-GA4	4mm
SS-12D11-GA5	5mm
SS-12D11-GA6	6mm
SS-12D11-GA7	7mm
SS-12D11-GA8	8mm
SS-12D11-GA9	9mm
SS-12D11-GA10	10mm

SPECIFICATIONS

- 1.RATING: 50V AC , 0.5A
- 2.CONTACT RESISTANCE: 200 mΩ Max
- 3.INSULATION RESISTANCE: 100 MΩ Min
- 4.OPERATING FORCE: 250 ± 100gf
- 5.LIFE:10,000 CYCLES

NO.	PARTS	MATERIALS	Q'TY	FINISH
7	STEEL BALL	STEEL	1	NATURAL
6	SPRING	STEEL WIRE	1	NATURAL
5	CONTACT	BRASS	1	Ag PLATED
4	TERMINAL	BRASS	3	Ag PLATED
3	CASE	PA9T	1	BLACK
2	COVER	SUS	1	NATURAL
1	KNOB	PA9T	1	BLACK

9	更新尺寸	Jack	110122
8	更新柄長選項	Jack	011420
7	新增PCB LAYOUT尺寸	Jack	010319
6	更新尺寸	Jack	112118
5	更新Rating	Jack	090418
4	更新材質	Jack	111517
3	新增PCB LAYOUT尺寸	Jack	092217
2	更新MODLE及PCB LAYOUT	Jack	012115
1	更新CONTACT RESISTANCE	Jack	111914
ITEM NO.	DESCRIPTION	DRAWN	DATE

東莞市高迪電子有限公司
DONG GUAN GAO DI ELECTRONICS CO., LTD

TOLERANCE UNLESS OTHERWISE STATED:

Up to 5 ±0.2
Above 5 ~ 15 ±0.3
Above 15 ~ 30 ±0.4
Above 30 ~ 50 ±0.5
Angle ±0.3°

3RD. ANGEL'S



UNITS MM

DRAWN BY:	DATE	MAT'L	TITLE	SWITCH
Jack Lu	11/01/22	FINISH	MODLE	SLIDE SWITCH
CHECKED BY:	DATE	SCALE	DWG NO.	SS-12D11-GAx-S191
Jacky Chen	11/01/22	SHEET NO.	PART NO.	SS-12D11-GAx-S191
APPROVED BY:	DATE	1 of 1		
Tony Kao	11/01/22			

SIZE A4
VER R9