

P.C.B LAYOUT
BOTTOM VIEW

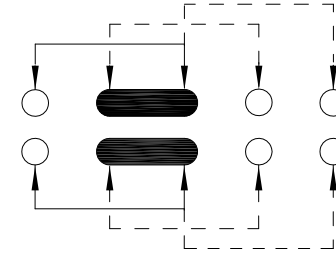

SCHEMATIC

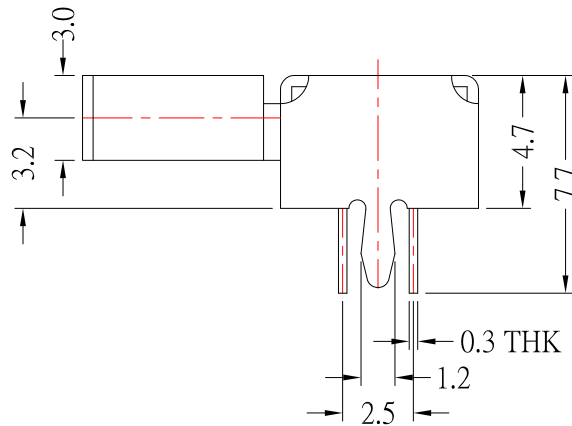
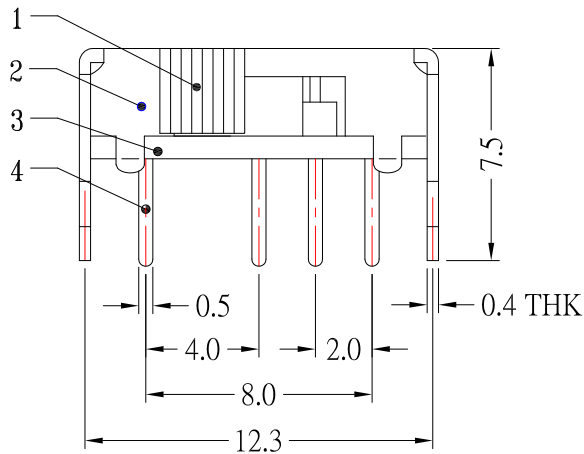

Model No.	X(mm)
SK-23D07-G2	2mm
SK-23D07-G3	3mm
SK-23D07-G4	4mm
SK-23D07-G5	5mm
SK-23D07-G6	6mm
SK-23D07-G7	7mm
SK-23D07-G8	8mm
SK-23D07-G9	9mm

SPECIFICATIONS

Rating	0.3A 50V DC
Function	2P3T
Timing	Shorting
Contact Resistance	200mΩ Max.
Insulation Resistance	100MΩ Min.
Operating Force	300gf ± 100gf
Operating Life	10,000 cycle

6	SPRING PLATE	PBS	1	NATURAL
5	CONTACT CLIP	PBS	2	Ag-PLATED
4	TERMINAL	BRASS	8	Ag-PLATED
3	BASE	PHENOLIC RESIN	1	NATURAL
2	FRAME	SPCC	1	Ni-PLATED
1	KNOB	POM	1	BLACK
NO.	PARTS	MATERIALS	Q'TY	FINISH

東莞市高迪電子有限公司
DONG GUAN GAO DI ELECTRONICS CO., LTD

TOLERANCE UNLESS OTHERWISE STATED :

Up to 5 ±0.2
Above 5 ~ 15 ±0.3
Above 15 ~ 30 ±0.4
Above 30 ~ 50 ±0.5
Angle ±0.3

3RD. ANGEL'S



UNITS MM

DRAWN BY:	DATE	MAT'L	TITLE	SWITCH
Jack Lu	11/19/14			
CHECKED BY:	DATE	FINISH	MODLE	SLIDE SWITCH Knob :3x3mm
Jacky Chen	11/19/14			
APPROVED BY:	DATE	SCALE	DWG NO.	SK-23D07-Gx-S191
Tony Kao	11/19/14	1 : 1		
		SHEET NO.	PART NO.	SK-23D07-Gx-S191
		1 of 1		
				SIZE A4
				VER R2

ITEM NO.	DESCRIPTION	DRAWN	DATE
2	更新Contact Resistance	Jack	111914
1	新增SPEC	Jack	081814