

P.C.B LAYOUT
BOTTOM VIEW

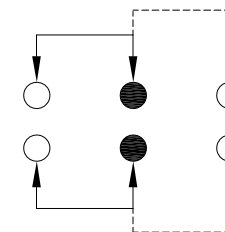

SCHEMATIC (NON-SHORTING)

Model No.	X(mm)
SK-22D06-G2	2mm
SK-22D06-G3	3mm
SK-22D06-G4	4mm
SK-22D06-G5	5mm
SK-22D06-G6	6mm
SK-22D06-G7	7mm
SK-22D06-G8	8mm
SK-22D06-G9	9mm

SPECIFICATIONS

Rating	0.3A 50V DC
FUNCTION	2P2T
Contact Resistance	200mΩ Max.
Insulation Resistance	100MΩ Min.
Operating Force	350gf ± 100gf
Operating Life	10,000 cycle

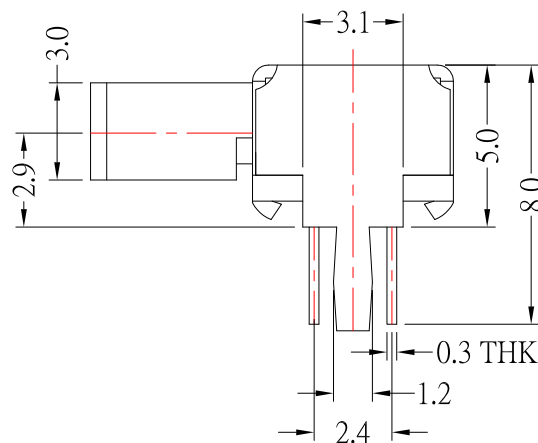
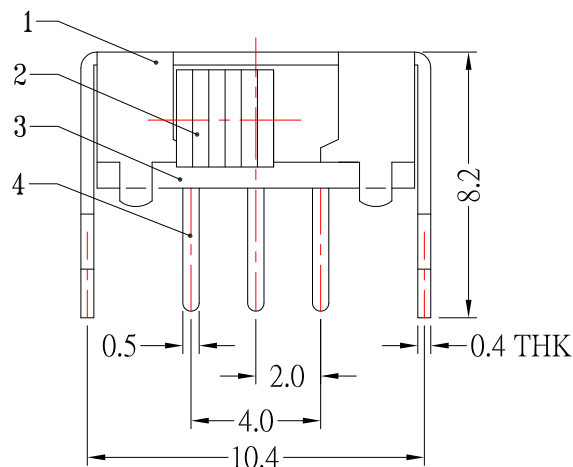

NO.	PARTS	MATERIALS	QTY	FINISH
6	CONTACT CLIP	PBS	2	NATURAL
5	SPRING PLATE	SUS	1	NATURAL
4	TERMINAL	BRASS	6	Ag PLATED
3	BASE	PHENOLIC RESIN	1	NATURAL
2	KNOB	POM	1	BLACK
1	FRAME	SPCC	1	Ni PLATED



TOLERANCE UNLESS OTHERWISE STATED :
 Up to 5 ±0.2
 Above 5 ~ 15 ±0.3
 Above 15 ~ 30 ±0.4
 Above 30 ~ 50 ±0.5
 Angle ±0.3

3RD. ANGEL'S



UNITS MM

DRAWN BY:	DATE	MAT'L	TITLE	SWITCH
Jack Lu	10/22/15			
CHECKED BY:	DATE	FINISH	MODLE	SLIDE SWITCH
Jacky Chen	10/22/15			
APPROVED BY:	DATE	SCALE	DWG NO.	SK-22D06-Gx-S191
Tony Kao	10/22/15	1 : 1		
		SHEET NO.	PART NO.	SK-22D06-Gx-S191
		1 of 1		

ITEM NO.	DESCRIPTION	DRAWN	DATE
1	新增SPEC	Jack	102215