

CIRCUIT DIAGRAM

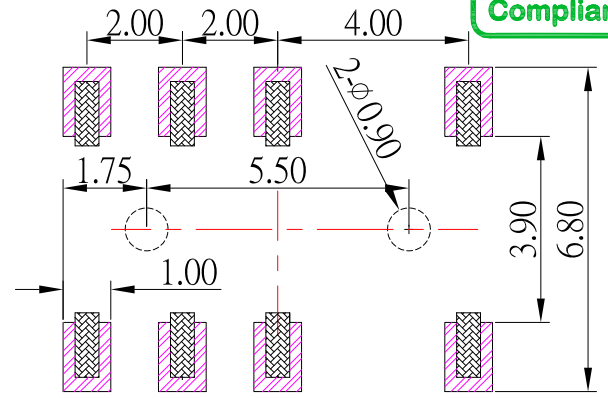

P.C.B LAND PATTERN

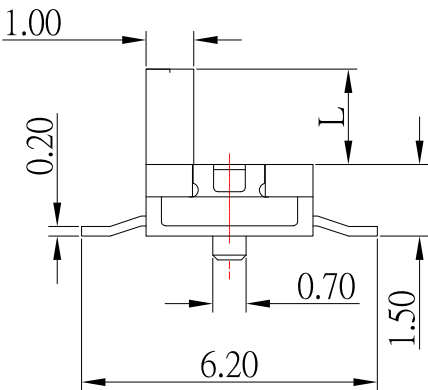
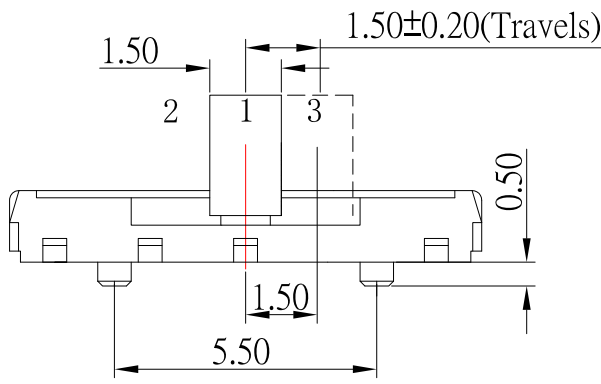

Model No.	L (mm)
SS-C91	1.0
SS-C91B	2.0
SS-C91C	3.0

SPECIFICATIONS

Rating	0.3A 4V DC
Insulation Resistance	50MΩ Min.
Dielectric Withstanding Voltage	AC 250 V(50Hz)1min
Contact Resistance	100mΩ Max.
Operating Force	200 ± 70gf
Operating Life	10,000 cycles

NO.	DESCRIPTION	QTY	MATERIAL	PLATING
E	TERMINAL	8	PHOSPHOR BRONZE	Ag plated
D	CLIP	2	BECU	Ag plated
C	COVER	1	STAINLESS STEEL	
B	CASE	1	LCP	Black
A	SLIDER	1	PA46	Black

ITEM NO.	DESCRIPTION	DRAWN	DATE
7	新增Travels及更新Operating Force和更新CIRCUIT DIAGRAM	Jack	113020
6	新增柄高選項	Jack	102020
5	更新外型樣式	Jack	041119
4	更新外型樣式	Jack	032819
3	更新外型樣式	Jack	030519
2	更新為AO版	Jack	062617
1	更新材質	Jack	111513



TOLERANCE UNLESS OTHERWISE STATED:
 Up to 5 ±0.2
 Above 5 ~ 15 ±0.3
 Above 15 ~ 30 ±0.4
 Above 30 ~ 50 ±0.5
 Angle ±0.3°

3RD. ANGEL'S



UNITS

MM

DRAWN BY: Jack Lu
 CHECKED BY: Jacky Chen
 APPROVED BY: Tony Kao

DATE: 11/30/20
 DATE: 11/30/20
 DATE: 11/30/20

MAT'L
 FINISH
 SCALE: 1 : 1
 SHEET NO.: 1 of 1

TITLE: SWITCH
 MODLE: SLIDE SWITCH
 DWG NO.: SS-C91x-S246
 PART NO.: SS-C91x-S246

SIZE: A4
 VER: R7