

P.C.B LAND PATTERN

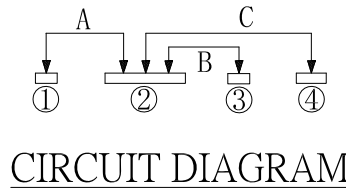
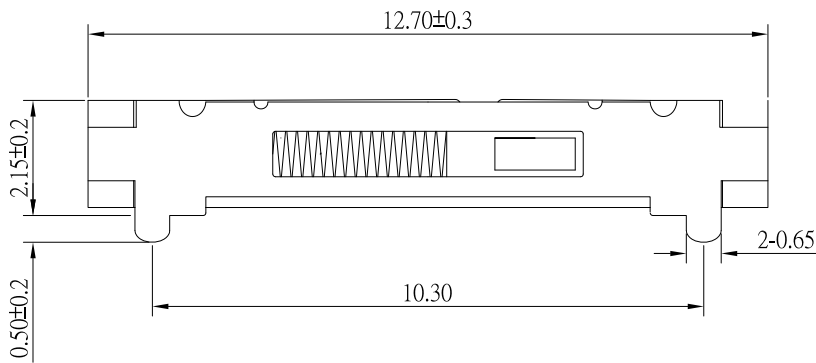

SPECIFICATIONS

Rating	100mA , 12V DC
Insulation Resistance	50MΩ Min.
Dielectric Withstanding Voltage	AC 250 V(50Hz)1min
Contact Resistance	100mΩ Max.
Operating Force	200 ± 70gf
Operating Life	10,000 cycles
Travel	2.0 ± 0.2mm

E	SPRING	1	SUS	
E	TERMINAL	4	PHOSPHOR BRONZE	Ag plated
D	CLIP	1	PHOSPHOR BRONZE	Ag plated
C	COVER	1	SUS	
B	CASE	1	LCP	Black
A	SLIDER	1	PA46	Black
NO.	DESCRIPTION	QTY	MATERIAL	PLATING

8	更新PCB LAYOUT中挖孔樣式	Jack	032124
7	更新圖面	Jack	102423
6	更新MODLE	Jack	010219
5	更新SPEC及材質	Jack	100814
4	更新為AO版	Jack	020514
3	新增SPRING圖示	Jack	011314
2	新增撥柄位置意識圖	Jack	010914
1	更新Rating	Jack	062813
ITEM NO.	DESCRIPTION	DRAWN	DATE



TOLERANCE UNLESS OTHERWISE STATED :
 Up to 5 ±0.2
 Above 5 ~ 15 ±0.3
 Above 15 ~ 30 ±0.4
 Above 30 ~ 50 ±0.5
 Angle ±0.3

3RD. ANGEL'S



UNITS MM

DRAWN BY:	DATE	MAT'L	TITLE	SWITCH
Jack Lu	03/21/24			
CHECKED BY:	DATE	FINISH	MODLE	SMT SLIDE SWICTH 左邊復歸, 2段固定
Jacky Chen	03/21/24			
APPROVED BY:	DATE	SCALE	DWG NO.	SS-C70R-1-S246
Tony Kao	03/21/24	1 : 1		
		SHEET NO.	PART NO.	SS-C70R-1-S246
		1 of 1		
				SIZE A4
				VER R8