

P.C.B LAND PATTERN

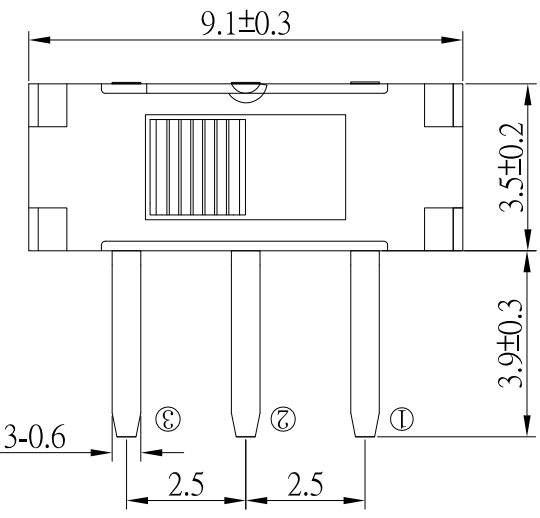

SS-B60x-B-S246

Model No.	X (mm)
SS-B60	2.0
SS-B60A	3.0
SS-B60B	4.5
SS-B60C	4.0
SS-B60D	5.0
SS-B60F	6.0
SS-B60K	7.0

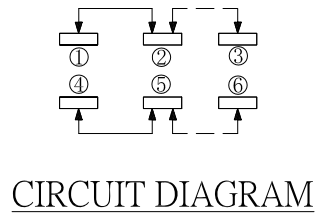

CIRCUIT DIAGRAM

SPECIFICATIONS

Rating	0.3A 6V DC
Insulation Resistance	50MΩ Min.
Dielectric Withstanding Voltage	AC 250 V(50Hz)1min
Contact Resistance	100mΩ Max.
Operating Force	200 ± 50gf
Operating Life	10,000 cycles

9	更新CIRCUIT DIAGRAM及新增高度選項	Jack	032521
8	更新樣式及尺寸	Jack	032119
7	新增尺寸"2.3"	Jack	041515
6	新增高度選項及更新料號	Jack	031215
5	新增高度選項3.0MM	Jack	111414
4	更新SLIDER COLOR :Black : B	Jack	022614
3	更新SPEC及材質	Jack	071513
2	更新料號	Jack	070413
1	更新Rating	Jack	062813
ITEM NO.	DESCRIPTION	DRAWN	DATE

10	更新CLIP材質	Jack	120522
----	----------	------	--------



TOLERANCE UNLESS OTHERWISE STATED :
 Up to 5 ±0.2
 Above 5 ~ 15 ±0.3
 Above 15 ~ 30 ±0.4
 Above 30 ~ 50 ±0.5
 Angle ±0.3

3RD. ANGEL'S



UNITS MM

NO.	DESCRIPTION	QTY	MATERIAL	PLATING
E	TERMINAL	3	PHOSPHOR BRONZE	Ag plated
D	CLIP	1	PHOSPHOR BRONZE	Ag plated
C	COVER	1	SUS	
B	CASE	1	PA6T	Black
A	SLIDER	1	PA46	Black

DRAWN BY:	DATE	MAT'L	TITLE	SWITCH
Jack Lu	12/05/22			
CHECKED BY:	DATE	FINISH	MODLE	SLIDE SWICTH
Jacky Chen	12/05/22			
APPROVED BY:	DATE	SCALE	DWG NO.	SS-B60x-B-S246
Tony Kao	12/05/22	1 : 1		
		SHEET NO.	PART NO.	SS-B60x-B-S246
		1 of 1		
			SIZE	A4
			VER	R10