

CIRCUIT DIAGRAM

P.C.B LAND PATTERN

SPECIFICATIONS

Rating	0.3A 6V DC
Insulation Resistance	50MΩ Min.
Dielectric Withstanding Voltage	AC 250 V(50Hz)1min
Contact Resistance	100mΩ Max.
Operating Force	200 ± 50gf
Operating Life	10,000 cycles

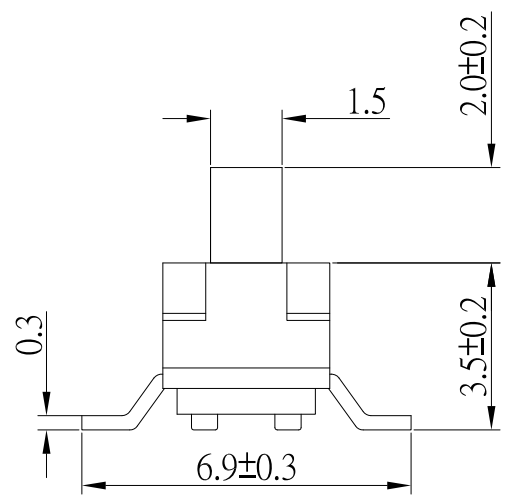
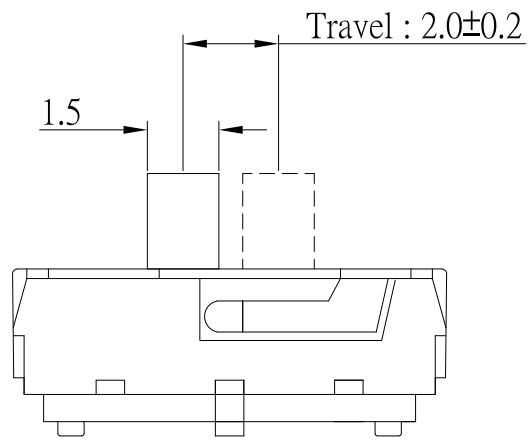

NO.	DESCRIPTION	QTY	MATERIAL	PLATING
E	TERMINAL	3	PHOSPHOR BRONZE	Ag plated
D	CLIP	2	PHOSPHOR BRONZE	Ag plated
C	COVER	1	SUS	
B	CASE	1	NYLON	Black
A	SLIDER	1	NYLON	Black

東莞市高迪電子有限公司
DONG GUAN GAO DI ELECTRONICS CO., LTD

TOLERANCE UNLESS OTHERWISE STATED
 Up to 5 ±0.2
 Above 5 ~ 15 ±0.3
 Above 15 ~ 30 ±0.4
 Above 30 ~ 50 ±0.5
 Angle ±0.3°

3RD. ANGEL'S

UNITS MM

DRAWN BY:	DATE	MAT'L	TITLE	SWITCH
Jack Lu	08/24/21		MODLE	SLIDE SWICTH
CHECKED BY:	DATE	SCALE	DWG NO.	SS-B35S-B-S246
Jacky Chen	08/24/21	1 : 1	PART NO.	SS-B35S-B-S246
APPROVED BY:	DATE	SHEET NO.	1 of 1	
Tony Kao	08/24/21			

ITEM NO.	DESCRIPTION	DRAWN	DATE
1	新增Travel	Jack	082421