

CIRCUIT DIAGRAM

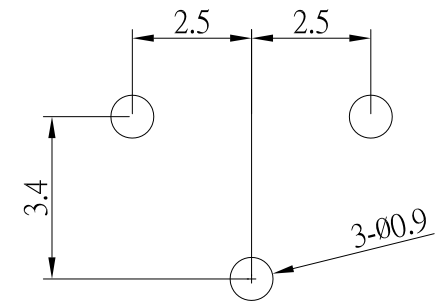

P.C.B LAND PATTERN

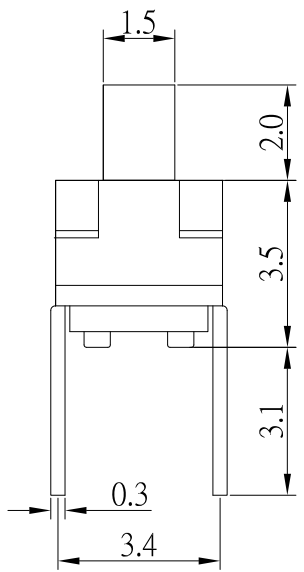
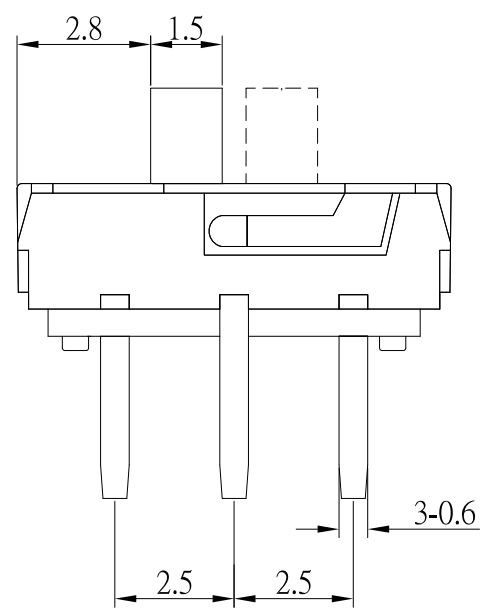

SPECIFICATIONS

| | |
|---------------------------------|--------------------|
| Rating | 0.3A 6V DC |
| Insulation Resistance | 50MΩ Min. |
| Dielectric Withstanding Voltage | AC 250 V(50Hz)1min |
| Contact Resistance | 100mΩ Max. |
| Operating Force | 200 ± 50gf |
| Operating Life | 10,000 cycles |

| NO. | DESCRIPTION | QTY | MATERIAL | PLATING |
|-----|-------------|-----|-----------------|-----------|
| E | TERMINAL | 3 | PHOSPHOR BRONZE | Ag plated |
| D | CLIP | 1 | BEUC | Ag plated |
| C | COVER | 1 | SUS | |
| B | CASE | 1 | PA6T | Black |
| A | SLIDER | 1 | PA46 | Black |



TOLERANCE UNLESS OTHERWISE STATED:
 Up to 5 ±0.2
 Above 5 ~ 15 ±0.3
 Above 15 ~ 30 ±0.4
 Above 30 ~ 50 ±0.5
 Angle ±0.3°

3RD. ANGEL'S

UNITS MM

| | | | | |
|--------------|----------|-----------|----------|---------------|
| DRAWN BY: | DATE | MAT'L | TITLE | SWITCH |
| Jack Lu | 07/18/13 | | MODLE | SLIDE SWICTH |
| CHECKED BY: | DATE | SCALE | DWG NO. | SS-B35-B-S246 |
| Jacky Chen | 07/18/13 | 1 : 1 | PART NO. | SS-B35-B-S246 |
| APPROVED BY: | DATE | SHEET NO. | | |
| Tony Kao | 07/18/13 | 1 of 1 | | |

| ITEM NO. | DESCRIPTION | DRAWN | DATE |
|----------|-------------|-------|------|
| | | | |
| | | | |
| | | | |