

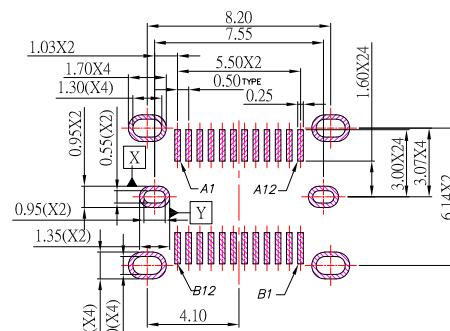

SBC-240VS1H-31x-S382

鍍層厚度:

Blank : 1u"
2 : 15u"
3 : 30u"

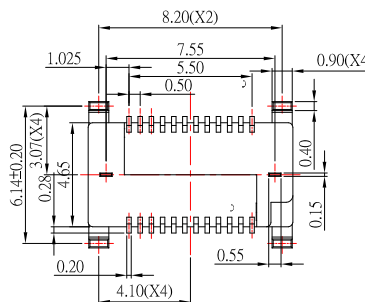
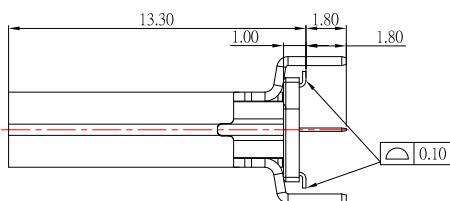
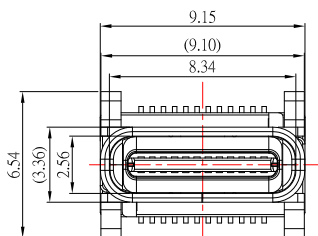
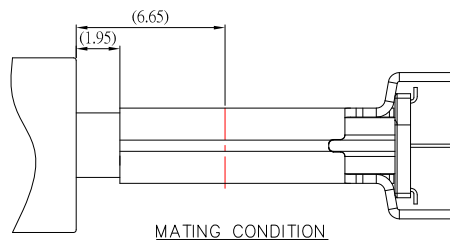
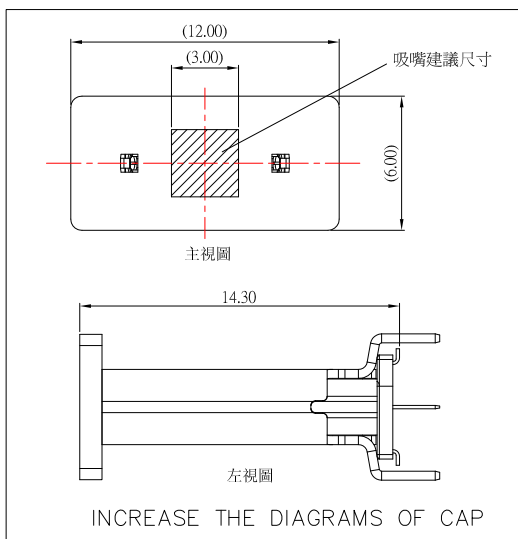

PCB LAYOUT

SPECIFICATIONS

Electrical:

- Rating: 5.0 V AC , 5.0 A for VBUS
0.25A for other
- Dielectric Withstand Voltage: 100V AC
- Contact Resistance: 40 mΩ Max
- Insulation Resistance: 100 MΩ Min

Mechanical:

- Connector Mate and Unmate Force
 - Mate force: 5~20 N
 - Unmate force: 8~20 N

Material:

- Housing: LCP
- Contact: Copper Alloy
- Shell: SUS

Finish:

- Contact: Plated Gold in Mating Area ;
Tin Plated on Solder Balls ;
Nickel under plated overall
- Shell: Nickel under Plated surface layer

Pin	Signal Name	Mating Sequence	Pin	Signal Name	Mating Sequence
A1	GND	First	B12	GND	First
A2	SSTXp1	Second	B11	SSRXp1	Second
A3	SSTXn1	Second	B10	SSRXn1	Second
A4	VBUS	First	B9	VBUS	First
A5	CC1	Second	B8	SBU2	Second
A6	Dp1	Second	B7	Dn2	Second
A7	Dn1	Second	B6	Dp2	Second
A8	SBU1	Second	B5	CC2	Second
A9	VBUS	First	B4	VBUS	First
A10	SSRXn2	Second	B3	SSTXn2	Second
A11	SSRXp2	Second	B2	SSTXp2	Second
A12	GND	First	B1	GND	First
SHELL	GND		SHELL	GND	



TOLERANCE UNLESS OTHERWISE STATED :
 Up to 5 ±0.2
 Above 5 ~ 15 ±0.3
 Above 15 ~ 30 ±0.4
 Above 30 ~ 50 ±0.5
 Angle ±0.3°

3RD. ANGEL'S



UNITS MM

DRAWN BY:	DATE	MAT'L	TITLE	CONNECTOR
Jack Lu	05/25/18		MODLE	USB 3.1 TYPE C 直立式 SMT L13.3MM 外殼腳長1.8 無定位柱 高導銅
CHECKED BY:	DATE	FINISH	SCALE	1 : 1
Jacky Chen	05/25/18		DWG NO.	SBC-240VS1H-31x-S382
APPROVED BY:	DATE	SHEET NO.	PART NO.	SBC-240VS1H-31x-S382
Tony Kao	05/25/18	1 of 1		
			SIZE	A4
			VER	A0

1	更新為A0版	Jack	052518
ITEM NO.	DESCRIPTION	DRAWN	DATE